

C · O · N · C · E · P · T 3 · D

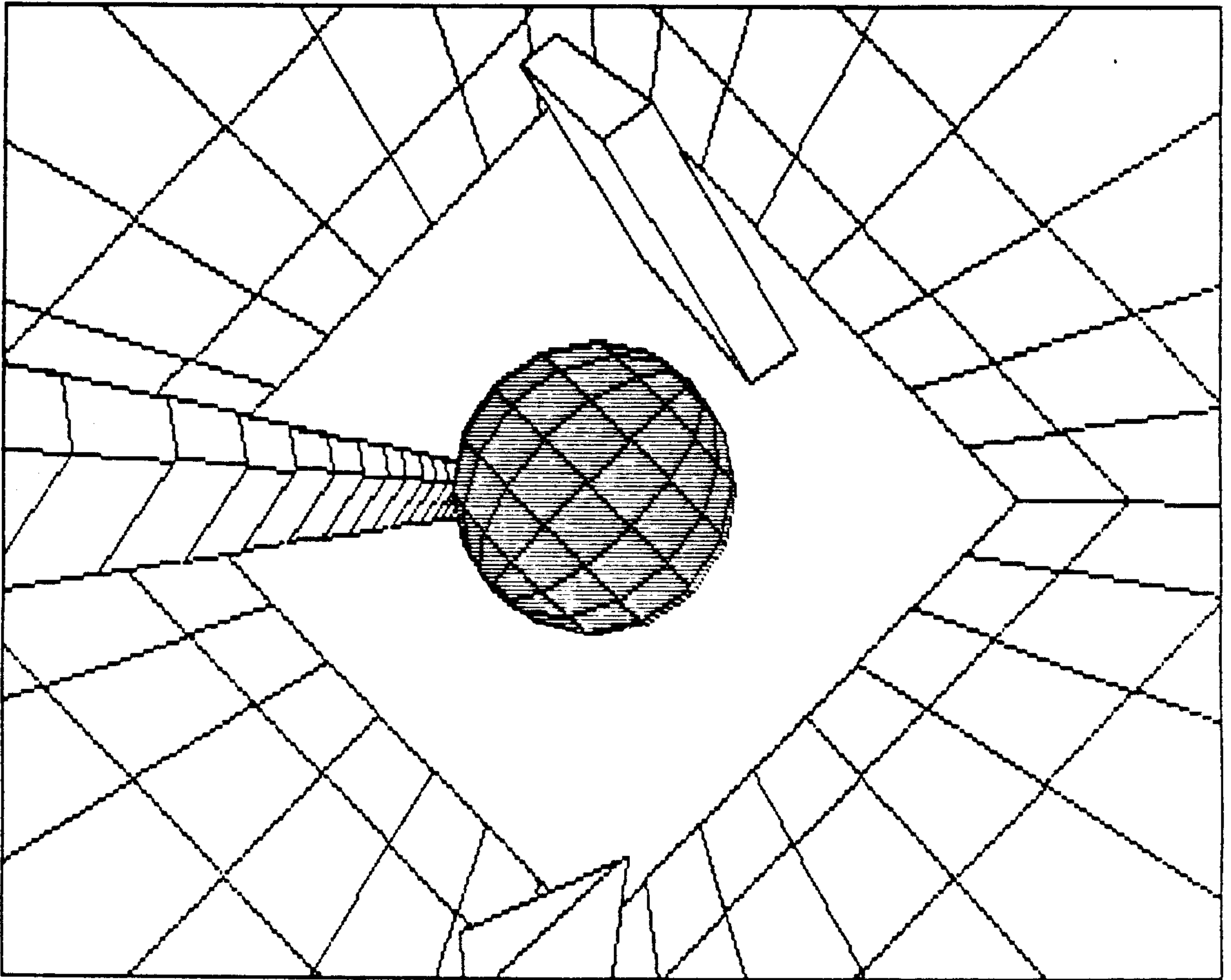

QL Graphics with an extra dimension

FROM TESSERACT SOFTWARE DEVELOPMENT

Distributed By CURRY COMPUTERS

CONCEPT 3D

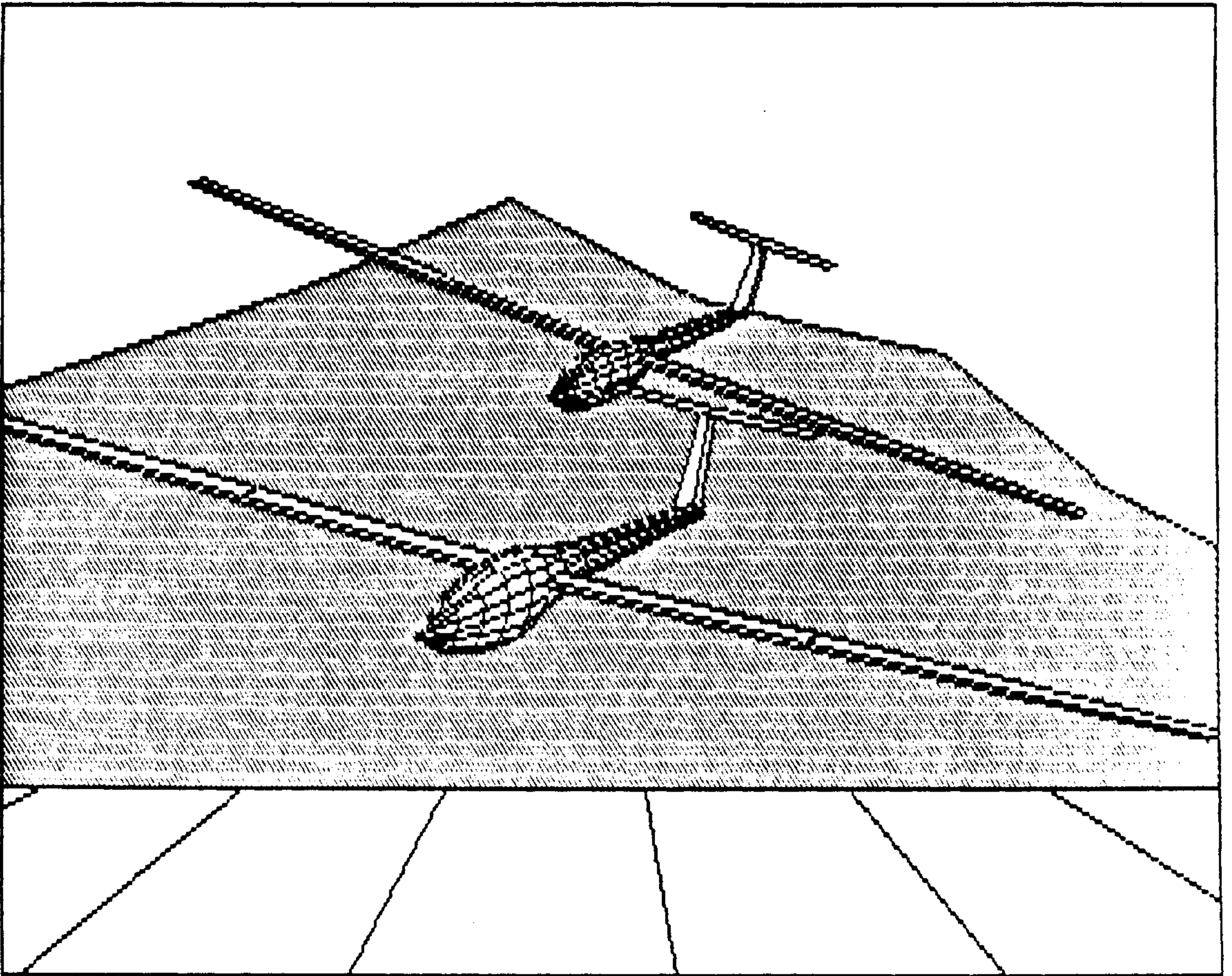

CONCEPT 3D version 1.0
Manual version 1.0

Copyright 1986 by Tesseract Software Development
2519 Bishop Avenue
Fremont, California 94536
USA

Contents

GETTING STARTED.....	1
CONCEPT BASICS AND 2D DRAWING.....	2
Moving the cursor.....	3
Views, rubber band.....	4
Scaling, math operators, drawing.....	5
Boxes, circles and ellipses.....	6
Deleting elements.....	7
Restoring elements, windowing.....	8
Zap.....	9
3 DIMENSIONAL MODELING.....	10
An introduction to 3D models.....	10
Cell models-constant cross section.....	11
Cell models-non constant cross section.....	12
Mixing types.....	13
FILE HANDLING.....	15
MORE 3D MODELING.....	17
Surfaces of revolution.....	17
Partial revolution.....	18
3D free form modeling.....	20
THE ROTATION MENU.....	21
THE DISPLAY MENU.....	23
Perspective.....	23
The demo in perspective, perspective windows.....	24
Surface modeling, line modeling.....	25
Override.....	26
Text.....	27
Screen dump.....	28
USING CONCEPT 3D.....	30
Manipulating models, locating points.....	30
Relocating points, relocating sets of elements.....	31
Scaling.....	33
Defining angles.....	34
Model attributes and stipple colors.....	36
Creating a sailplane.....	37
More about surfacing models.....	39

Getting started

Welcome to the 3 dimensional world of CONCEPT 3D. We hope CONCEPT will give you new and better ways to express your ideas with your computer. CONCEPT lets you create images that are dynamic objects, not just static screen drawings.

This manual is written for those who have no experience with 3D graphics. While it is not strictly a tutorial, it is best read with CONCEPT running in your QL so you can work through the examples given. There is very little memory work required to learn CONCEPT. The program consists of a number of simple commands that do specific tasks. Each command is prompted by a word or statement that describes its function.

To give you an idea of what CONCEPT is all about, let's take a look at the demonstration file on the cartridge. To start the program, you must first make a backup copy using the BACKUP program on the CONCEPT cartridge. Place the cartridge in drive 2 and a blank cartridge in drive 1. Type LRUN MDV2_BACKUP to start the program. You may choose whether or not to format the cartridge in drive 1; if you choose to format you will be asked to input a volume label, and the cartridge will be formatted 5 times before copying. You may make as many copies as you want on disk or microdrive.

To run CONCEPT place the master in drive 2, your backup in drive 1, and boot up the QL using F1 or F2. Press any key once the program reminds you to put the master in drive 2 and CONCEPT will run for you. We'll explain the screen format later in the manual; for now just press (CAPS) F to get into the FILES area. CONCEPT commands are all single key entry; any capitalized commands in the bottom screen line require a caps shift. Take the master out of drive 2 and replace it with your backup. Now press 1 to load and enter demo. After a bit, the front view of a racing sailplane begins to appear.

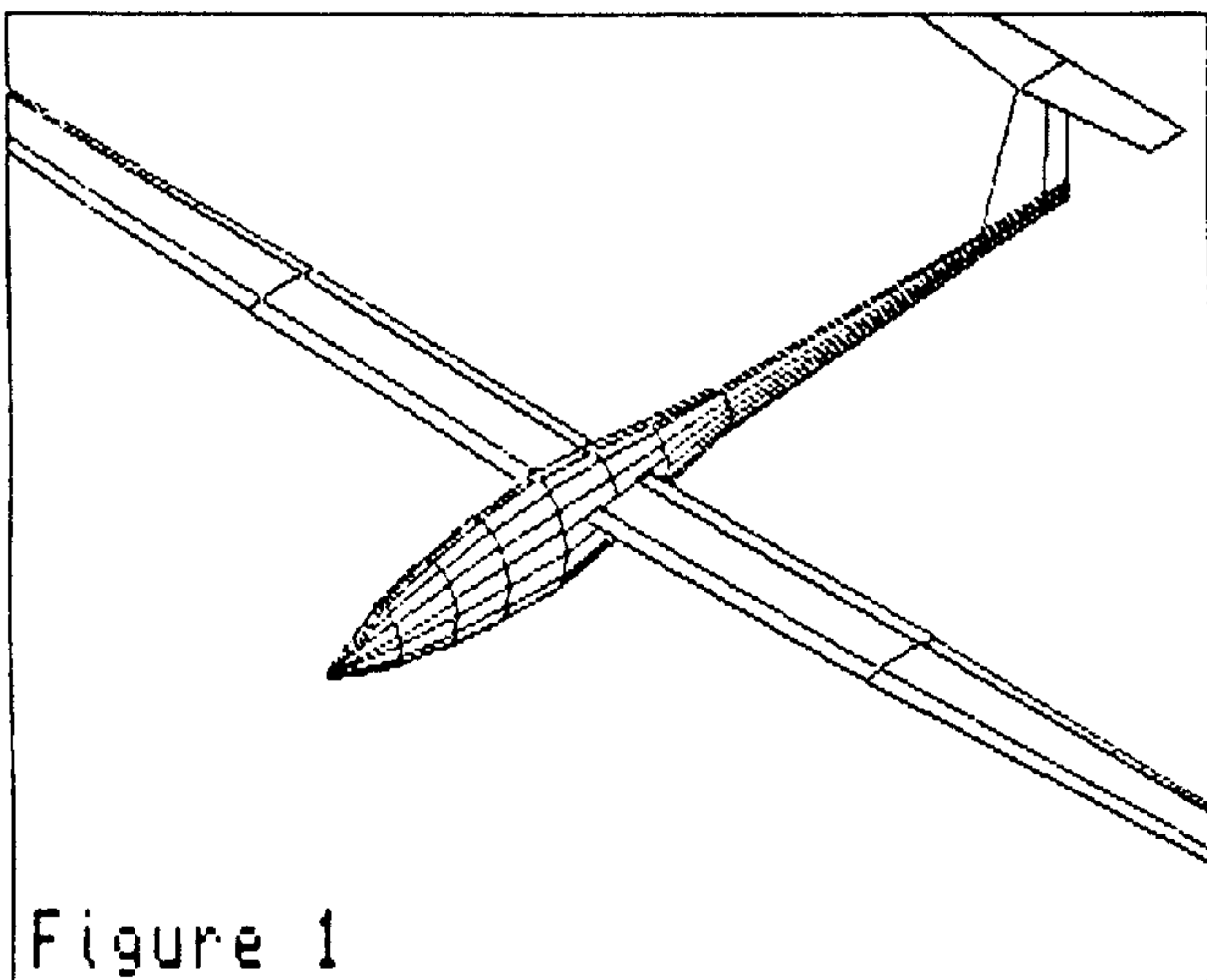
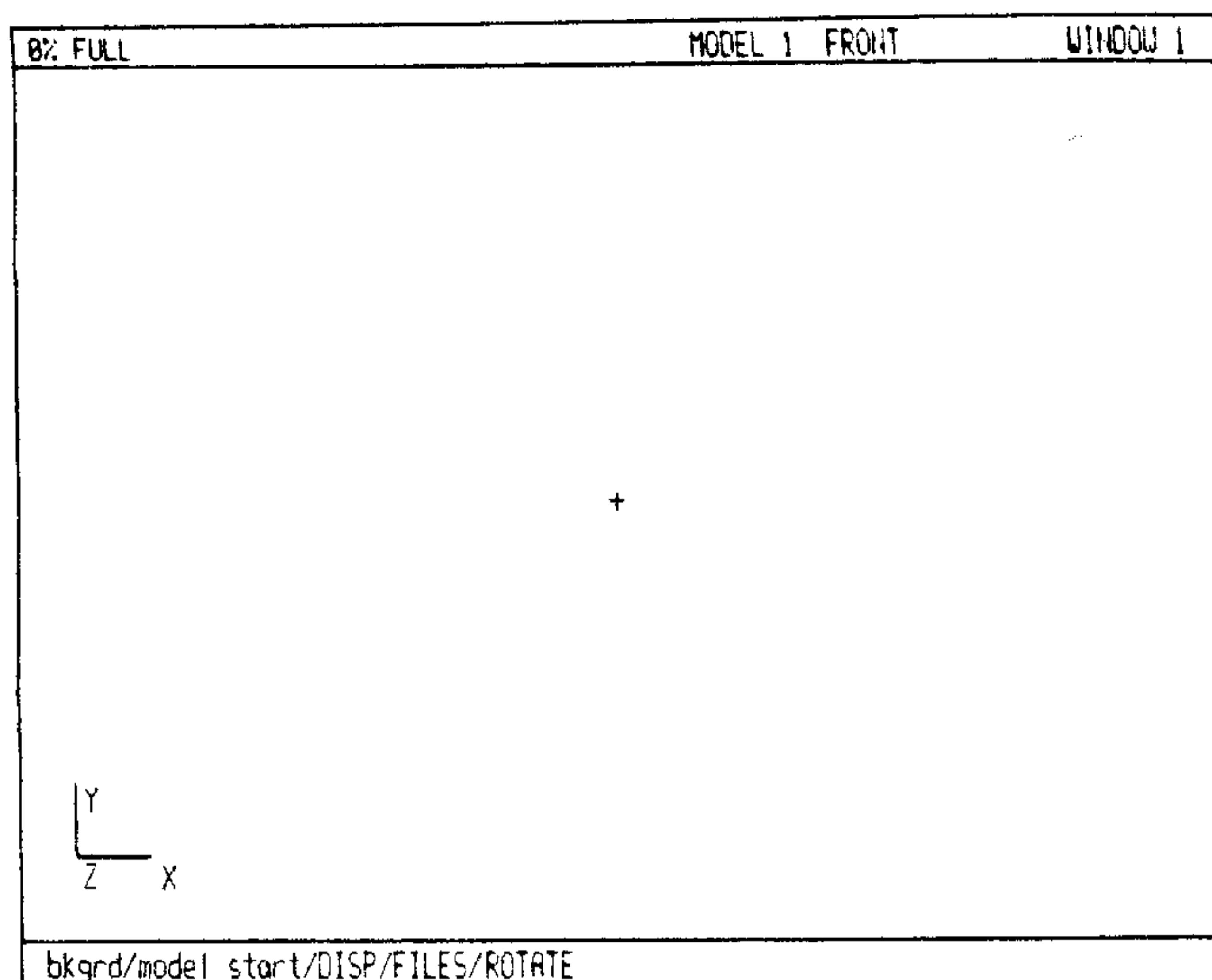

Figure 1

Now let's take a look at a rotated view. Press (CAPS) R for rotation then 1 to call an isometric view. Once the plane is redrawn in its new orientation, press s and the sailplane will be redrawn with hidden surfaces removed. Figure 1 shows the sailplane in isometric with hidden surfaces removed.

As you go through the manual, you will want to look again at the sailplane as you learn how to zoom in and out, rotate it into other orientations, view it in perspective, take the plane apart and put it back together again. At the end of the manual, we will show you how the sailplane was created and why it was created that way.

CONCEPT basics and 2D drawing



Once the program is loaded as we showed you how to do in the last section, you should see what is in Figure 2, a black screen, white cursor, red information line at the top, a green command line at the bottom and the reference coordinate axes at the lower left of the window. High and low resolution displays are shown here; normally we will show only high res.

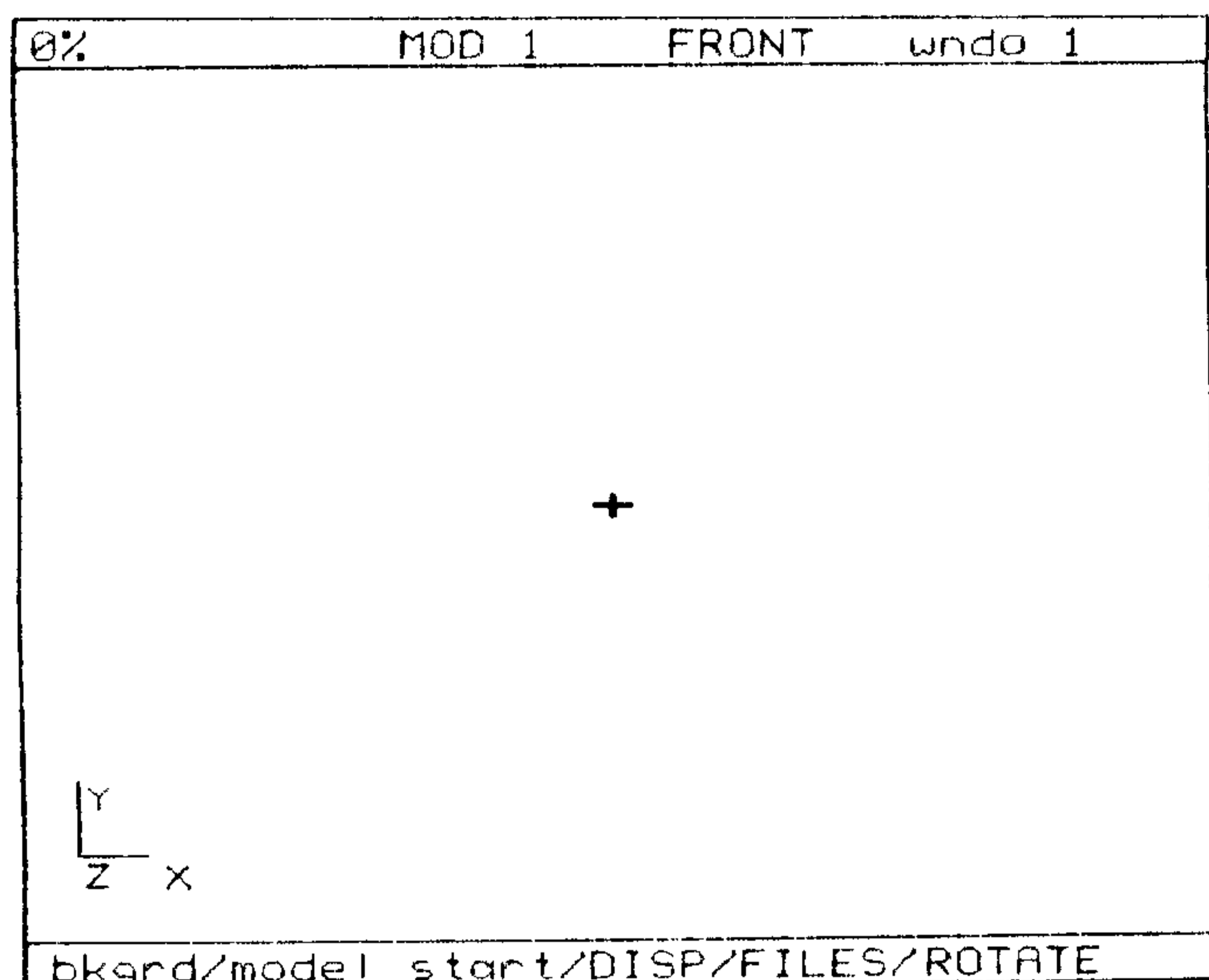

The red information line shows how full the memory is getting, the current model, which of the three main views you are looking at, the window size, and a few other things, all of which we will explain as we go along.

The green command line lists a menu of prompts of the commands that are available. We are looking at the Create Menu; there are several others which we will discuss later. At this point in the program there are 30 available

Figure 2

commands; slashes separate the prompts in the command line. Press **F3** a few times to run through them and come back to the original line. All functions listed are active in this graphics creation section of the program whether or not they are currently displayed in the command line. To call a command, just press the first letter of the prompt or the function key indicated by the prompt. If the prompt is capitalized in the command line, the QL expects a caps shift key to be pressed. Earlier when loading the demo, we pressed **F** to get into the files section. For another example, one of the commands available is called hi-lo. This toggles the high resolution (4 color) and low resolution (8 color)

screens. Press **h** a few times to see this in action. In general, **CONCEPT** uses single key entry for all commands, and it uses the **ENTER** key to input all numbers.

We will highlight the prompts in the same way they are listed in the command line as we discuss how to call and use them. We will also highlight any other key inputs you will make.

Moving the cursor

The only commands not in the prompt line are those we will discuss first, namely the **cursor** and **jump** keys. The cursor as you might guess, is the position that points are plotted to and lines are drawn to, and it moves just as you would expect with the up, down, left, and right cursor keys or the joystick. The jump keys are simply 1-9 on the top row. Press one of them and that is the number of pixels the cursor will move for each repeat of the cursor keys or joystick. This sets the accuracy of the cursor motion relative to a point, but it is more useful for getting from one place to another quickly.

The other way to move the cursor is by keying in x, y, or z values (**/x/y/z/** in the command line). The x, y, and z directions make up **CONCEPT'S** 3D coordinate system.

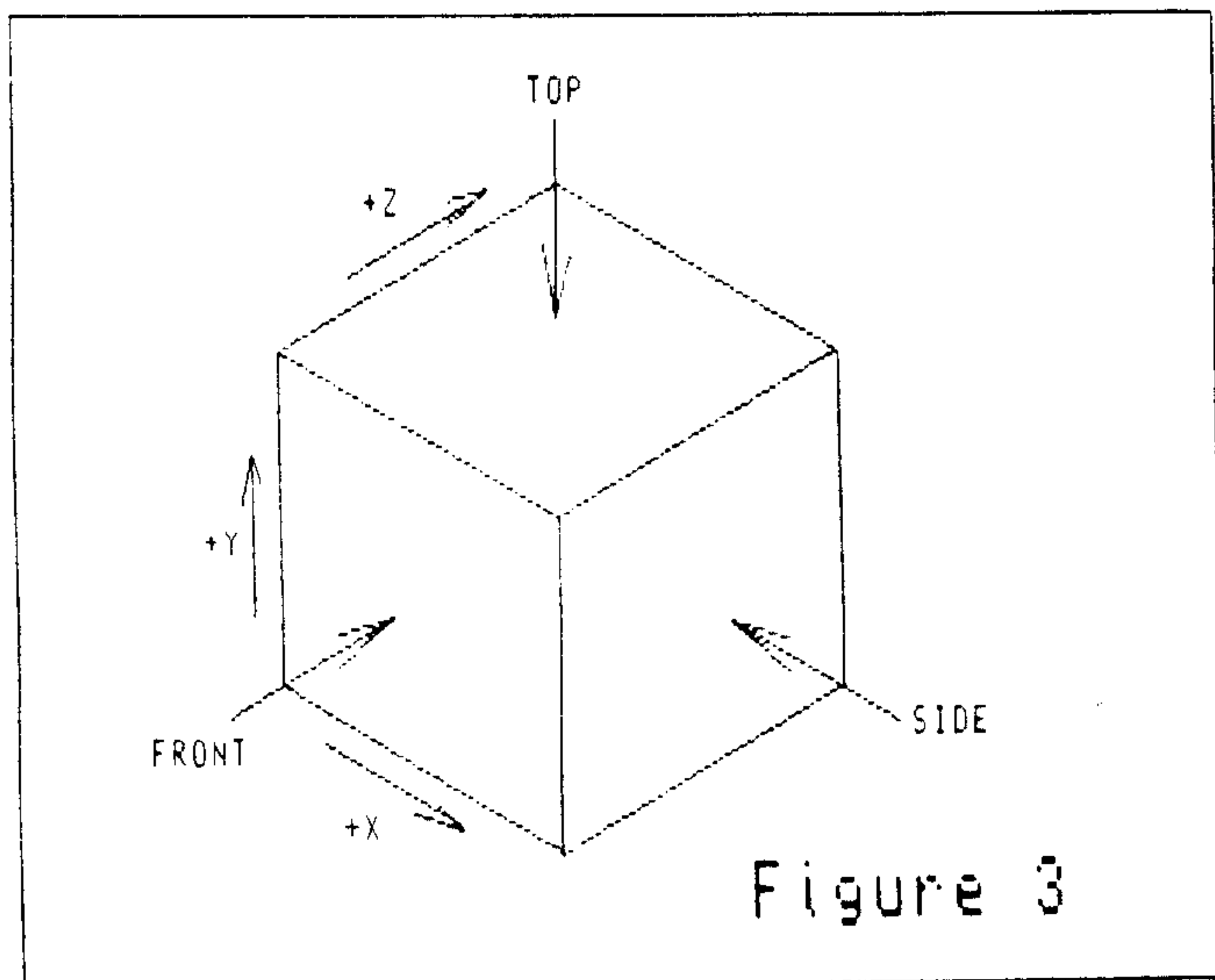

If you had geometry classes in school, you might remember that x, y, and z are standard labels for width, height, and length. Figure 3 shows the x, y, and z directions and their relationship to the front, top, and side views.

Press **f** to get into the front view (front, top, and right side views are **/front/top/side/** in the command line). The directions of x, y, and z are shown in the lower

left corner by the reference axes. These are always displayed when you are creating or rotating models. Notice that x and y are displayed in green, and z is displayed in red. Axes displayed in green are either coming out at you or are running parallel to the screen; axes that are red are running into the screen away from you. So in the front view, positive x is to the right, negative x is to the left, positive y is up, negative

down, and positive z is into the screen, negative coming out at you with $z=0$ right at the screen plane. The initial position of the cursor at startup is $x=0$, $y=0$, $z=0$.

If you have not had your fill of math classes, you may not have had much to do with negative numbers. They are indispensable to mathematics and to CONCEPT. In CONCEPT negative numbers simply represent a direction, the opposite direction of positive numbers. In many of your models, as much of the model will be in the negative area as in the positive area, but that will make no difference to the model or to you.

Let's try keying in a 3D cursor position. Press **x** (notice that the current value of x is displayed) and enter 50. The cursor snaps to $x=50$. Do the same for y and z . Now the cursor is on $x=50$, $y=50$, and $z=50$. You cannot see any change in the z position of course, since it moved directly into the screen, but if you press **z**, the current value is displayed.

Views

If you pressed **z** to check its value, press **ENTER** to get back to the Create Menu without changing anything. The other way to find the z point is to go into another view. Press **s** to view from the right side. In the reference axes, y is still up but positive z now goes to the right and positive x now comes out of the screen at you (all axes are green). Our eyepoint has been rotated from the front viewing position to a view of the right side of the drawing space; if this is not clear, refer to Figure 3. Now take a look at the top view of our drawing space (I know, the view is still just a cursor in the middle of the screen...but hang on) and see from the reference axes that it is a view starting from the front and tilting 90 degrees to the top with the z direction going up (positive) and down.

Rubber band

Getting back to our 3D cursor position, the reason the cursor is centered on the screen when you change views is so that the area that you are working on in a large drawing is always centered on the screen. To find where we are relative to our initial $0,0,0$ position, press **F2** (**/F2band/**) and you will see a "3D rubber band" going from point $0,0,0$ to the cursor position of $50,50,50$. Take a look at each view and refer to Figure 3 to make sure that you understand the relative position of the points as shown by the rubber band. If you understand what we have drawn so far you will have no difficulty in visualizing view orientation with an actual object on the screen.

The rubber band always points back from the cursor to the last point plotted or the last line drawn. F2 turns the rubber band off as well as on. CONCEPT also turns the band on and off at what it considers logical points; you may always override it using F2. You will probably find the rubber band feature very handy for previewing what you are about to draw.

Scaling

It should be mentioned that the numbers we are working with correspond to pixels in the full scale window. CONCEPT does not include millimeter or inch scaling factors because everyone's monitor and printer are different. If you want to set up your own scale based on measurements of your output device, you can use the constant **k** (/k/) as a multiplier. Press **k** to enter a value or find what the current value is (it is initially set at 1). Entering a value for **k** or just ENTERing returns you to the Create Menu and cursor. Now any time you use **k** when entering numeric values, you are actually using the number that **k** represents. Of course **k** can be used any time you will use a number repeatedly.

Math operators

CONCEPT will accept inputs with a mathematical operator. The operators are +, -, /, *, and ^ (raise to a power). For example keying any of the following after an input cursor in the command line:

```
3*4.26
6.923+k
k/2.22
3.51-31.92
4.7^2.89
```

is acceptable and all will have their indicated values. CONCEPT will not accept the following:

```
6.2/0      Division by 0 is undefined
k*(4+3)    Too many operators & no parenthesis allowed
5-A        Only k can be defined as a number
```

These rules hold true whenever a numeric input is called for.

Drawing

Now that we know the rules, let's draw a simple 2D box. Just so we are all in the same place, get into the front view by pressing **f**. CONCEPT objects are called models and they are made up of points, line, circles, and ellipses. Every model that is made up of lines must be

started with a point. Start at our previously set up coordinate (x, y, and z all 50) and press **p** (**/p/**) to establish a point. You should have gotten an error message saying that you need to start a model. We pointed this out in this way to dramatize the fact that CONCEPT needs to know information about what kind of model is to be created, and it does that by requiring that objects or parts of objects be defined as models. Within the model definition are various attributes such as model color, model type, and position in the data field. All of this is behind the scenes except the choice of colors. We are going to create a 2D model now; for a description of how models are used and what types of 3D models are available, see the beginning of the 3D section. CONCEPT allows a maximum of 50 models. Press **m** (**/model start/**) to start the model. Enter a color number from 0 to 7 (4 color/8 color definitions apply here, see your QL user manual. Also there are stipples available here, but we will get into that later). By the way, if you had pressed **m** by mistake, an **ENTER** would have returned you to the cursor without starting a model. Notice that the model note at the top now indicates model 1; it always shows the current model being worked on.

Now that we have started our model, key **p** to establish the coordinate point. Now move the cursor to $x=-50$, leaving y and z as they were. If the rubber band was not on before, it will be now. Press **F5** (**/F5draw/**) to draw the line. The rubber band indicates where the line will go and **F5** establishes the line in the model color you selected. **F5** has established a coordinate point at the cursor position but it is defined as the end of the line. If you had pressed **F5** without starting with a point, you would have been requested to start with a point. Now move the cursor to $y=-50$ and draw with **F5**, then $x=50$ and draw, and finally connect the box together by drawing a line to the initial point at $y=50$. You should have a 100 by 100 box in the middle of your screen.

Boxes

We had you make a box by drawing the individual lines so that you would learn how to draw with CONCEPT. The same box could have been created using the **BOX** command. Press **B** and enter a width and height, and a rectangle is centered on the cursor. If you key **B** by mistake, press **ENTER** instead of a width or height and you will be returned to the Create Menu.

Circles & ellipses

We can now demonstrate how the circle and ellipse commands work. Move the cursor to the center of the box

($x=y=0$) and key **c** (/circle/). As the prompt indicates, you can get circles and ellipses at this point. Let's make a circle first; key another **c**. Enter 80 for the diameter. Now you are asked for the angle of tilt. This is used for creating tilted ellipses, but it also defines where the start point of the circle is. Later we will show why that is sometimes useful. For now just enter 0 which corresponds to a starting point at the 3 o'clock position. The circle is drawn counterclockwise as a series of short straight line segments starting with a point. 16 lines and the starting point make a circle or ellipse for a total of 17 coordinate points. When we do some surface modeling you will see that all CONCEPT models are made of straight line segments called facets. The models are called faceted models.

Now let's place an ellipse around the outside. Using the same center point, key **c**, then **e** for ellipse, and enter 200 for the major diameter. The major diameter is the width of the ellipse along the tilt axis; the

horizontal width for a 0 degree tilt (see Figure 4). The minor diameter is at 90 degrees to the major diameter; enter 70 for this value. Now enter 45 degrees for the tilt angle and your screen should look like Figure 5.

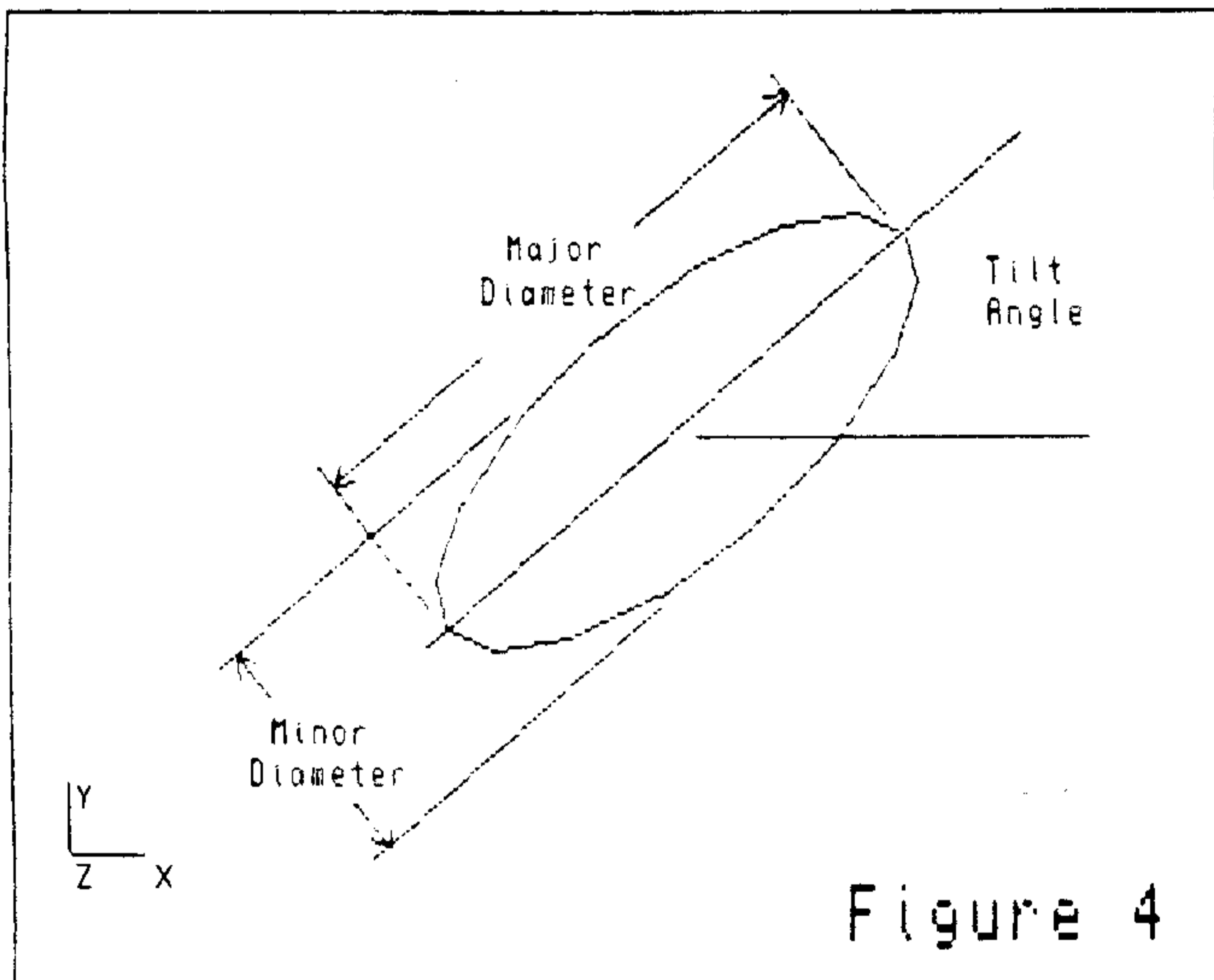

Deleting elements

Since nobody's perfect, CONCEPT has a way of deleting all or part of what you just did. Press **F4** (/F4del/) to delete the last line

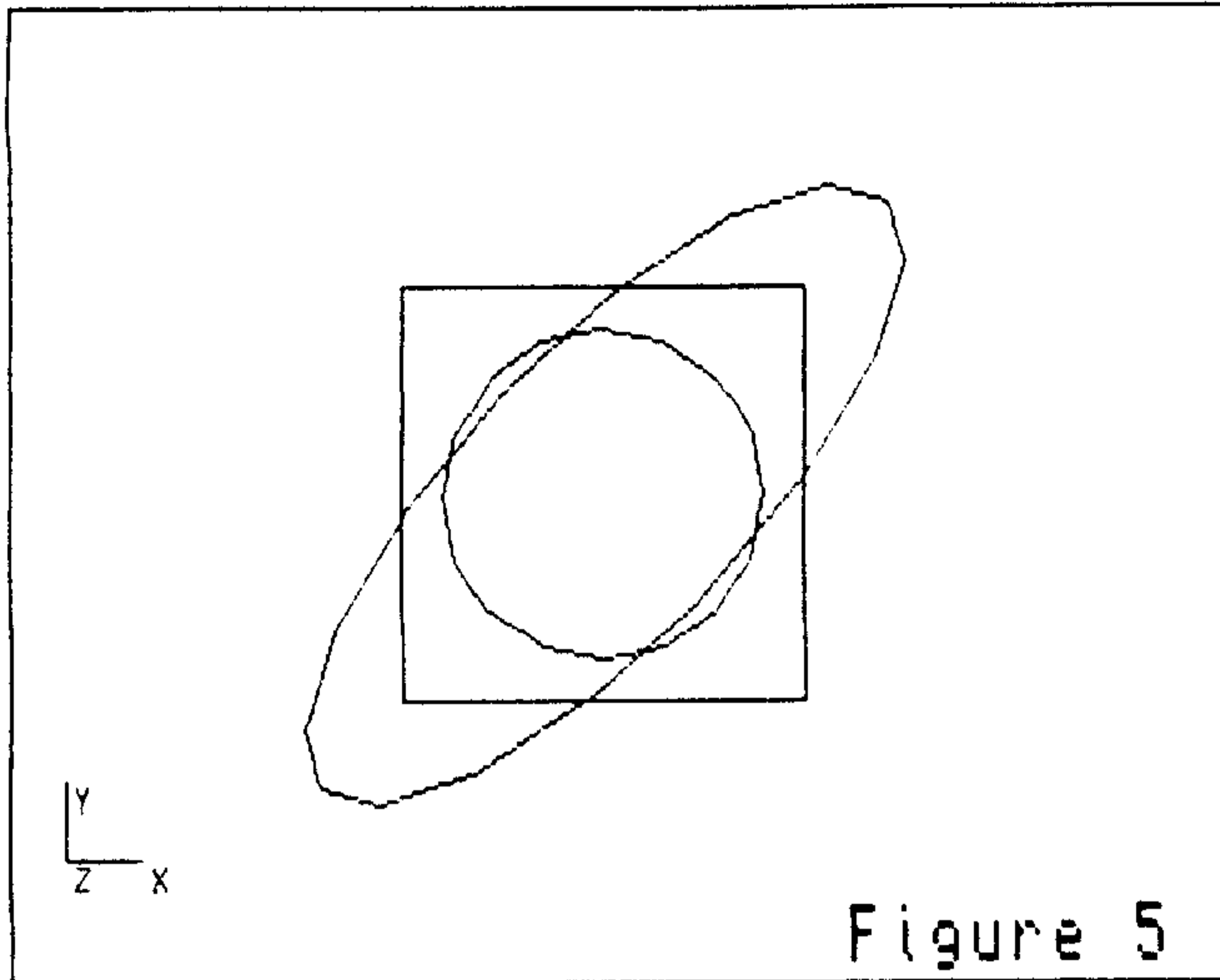

drawn; in this case a segment of the ellipse. Keep pressing **F4** and you delete more of the ellipse. Wherever you are in the destruction of the ellipse, if you pressed **F5** (don't do it) you would be starting to create your model again and you would get a line from the end of the last remaining model line to the cursor. Using **F4** you can delete all of the lines and all but the first point in the model, but not the model itself. We will discuss

how to do that later.

Restoring elements

Also since nobody's perfect, CONCEPT has a way of bringing back what you may have deleted by mistake as long as you did not create anything since you last pressed **F4**. Press **[shift] F4** (**/[F4]rstr/**) and the last line deleted comes back. Leave the key down and the whole model will come back. It is important to remember that if you delete some of a model, create a few lines, delete them, and then try to get all of the original model back, you will end up with a strange mixture of old and new model.

Windowing

Before we leave the world of 2D, you have probably noticed the "WINDOW 1" note in the right side of the information line. The 1 refers to the viewing scale of the display. The **/window/** function, called by keying **w**, allows you to change this factor. Try keying **w** and entering 2 for a window factor. The screen is redrawn in half scale. Think of the window factor as units of viewing distance away from the model; the model is full scale when viewed from 1 unit away, 1/5th scale with a factor of 5, and 4 times larger than full scale with a factor of .25. Now window out (that is, use a large enough number) so that you can see the entire drawing and move the cursor to some other location on the screen. Now press **w** and **ENTER**. The cursor position is the same relative to the models displayed but it is now at the center of the screen with no change in window factor just as it was earlier when we changed views. If you move the cursor, key **w**, and change the window value, then the

screen will center on the cursor and be redrawn at the new viewing scale. Using the window command, you can look at any part of CONCEPT's very large drawing area since you can set the cursor to a point off the screen and use window to move the screen to it. If you know that what you want is just a little ways off the screen, simply window out to bring it into view. The window command may be used at any point in the creation of models to bring points into view, zoom in on them, etc.

Throughout this manual we will use "window out" to mean backing away from the models and "window in" to mean getting closer to them. "Window around" means moving up, down, or sideways relative to the models.

One note of warning while we are on the subject of windows. Entering a very small number as a window factor has the effect of blowing up the screen image enormously. Most of your model is then drawn off of the screen; portions could easily be several kilometers away! This slows the QL to the point where it could hang up indefinitely. The same situation could arise when entering a cursor position that is too far off the screen. We have not locked you out of these situations in CONCEPT because that might limit the flexibility of the program in other less dangerous situations. The best thing to do is to approach these extremes cautiously.

Zap

When we start learning about 3D in the next section, we could turn the 2D model that we have created into a 3D model, but we might be wiser to start with something a little less challenging to visualize. Which gives us a chance to look at an important command called /ZAP/. ZAP is used to delete a model or all models, so it needs to be used carefully. Press Z (remember the caps) to look at the prompt. Pressing d and entering the model number will delete the model and pressing e or r is self explanatory, r being used to return from a mistaken ZAP call. We only have one model at this point but press d anyway and we will look at what happens. When model number 1 is entered, nothing happens to the screen. The screen does not redraw until you pressed f, s, or t to call a view. This is done so that you can delete several models in a row without having to wait for a redraw each time.

Let's say you have 5 models and you want to delete numbers 3 through 5. If you start by deleting number 3, you need to realize that CONCEPT rennumbers models 4 and 5 to be numbers 3 and 4 so there are no "holes" in the model structure. So instead of deleting 3, 4, and 5 in turn, you would want to delete number 3 three times. The other way to do it would be to delete #5, then 4, then 3.

3 dimensional modeling

An introduction to 3D models

Knowing when and how to create 3D models is the key to using CONCEPT effectively. A CONCEPT model is a collection of 3D points and lines that fall into one of 3 categories. The computer understands how to display each of these 3 types of models so all we need to do is tell the computer which type of model we are creating. The 3 types of models are cell models, surfaces of revolution, and free form models. All of these will be discussed in detail in the following pages, but we will introduce them here.

Cell models consist of a collection of 2 dimensional figures connected together by the computer. The

connected figures form a series of cells. For example Figure 6 shows a rotated view of a single cell model. Two boxes were created at different depths and when the screen was redrawn, the coordinates were connected together to make a single 3D model. The computer was told that the model was to be a cell model right after the first box was drawn.

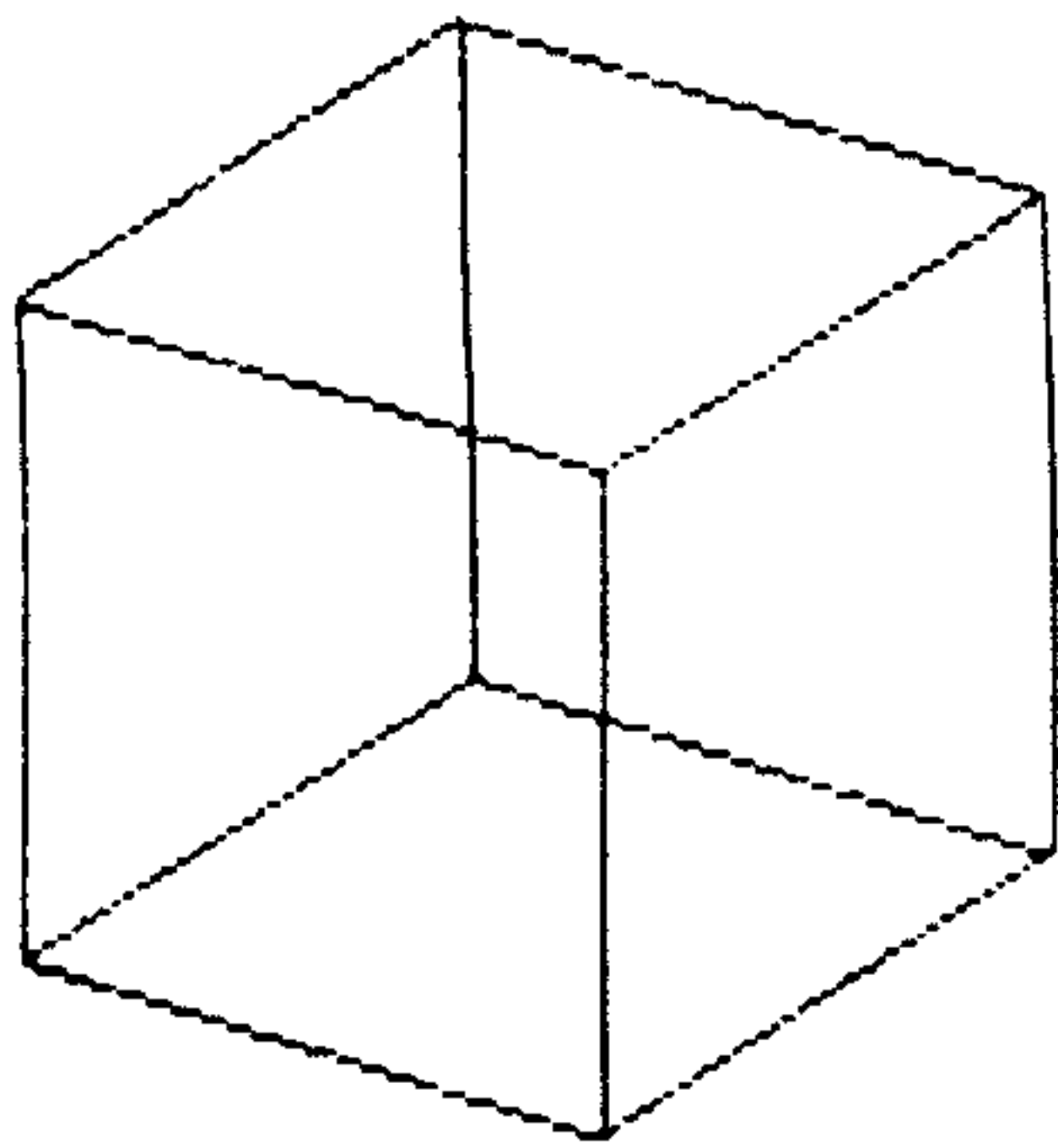

Figure 6

A surface of revolution is treated by the QL in exactly the same way as a cell model, but it is created differently. Figure 7 shows a wine glass created as a surface of revolution. You can see that the model really is a cell model. To create the glass, lines were drawn between the side coordinates then the computer took over and drew the rest of the glass by sweeping the coordinates around a pre-determined center line. For models with a circular or partially circular cross-section, a surface of revolution is a very easy way to do the creation.

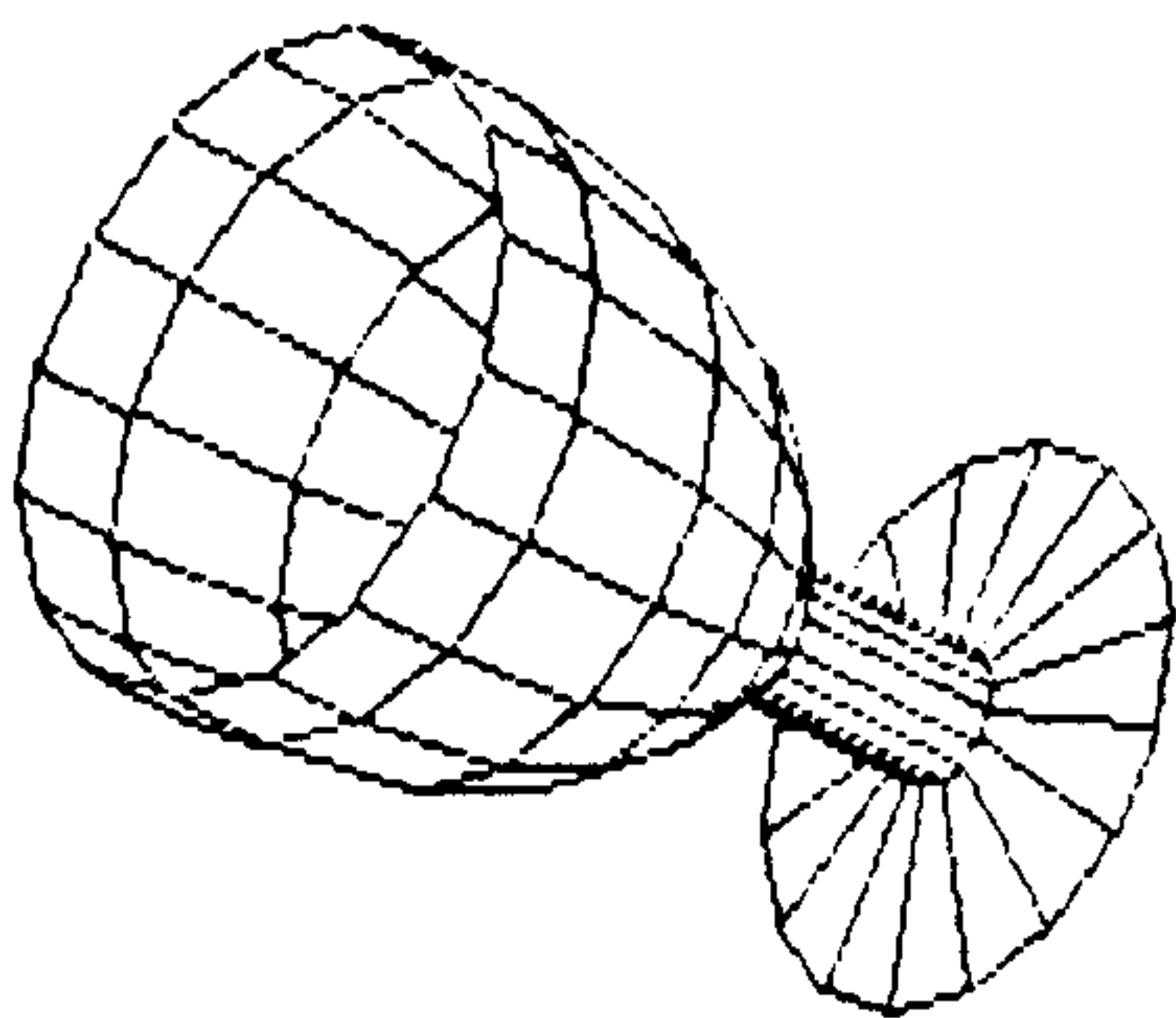

Figure 7

The third type of model is a free form model. In this type, all of the points and lines required to create the model are drawn in 3D space, and the QL works with the model as it is drawn rather than trying to add connecting lines. Free form modeling is used for 3D artwork or when there is no other way to model the object you have in mind.

Cell models - constant cross section

A constant cross section cell model is one whose shape and size does not vary when looking at an end view. Boxes and cylinders are examples of objects with a constant cross section; if you look at them from one end, there is no change in their shape from one end to the other.

Start a new model and make a rectangle at $z=0$ (we are in the front view). The drawing by the way, does not have to be a closed section like a rectangle, and it does not have to start at $z=0$. The rectangle drawn defines the cross section of the box, and we will turn this into a 3D rectangular box made up of 3 cells using the `/CELLS/` command. Press `C` and then `y` at the `y/n` to indicate a constant cross section. Now you are prompted to define the model as an open or closed section. If our box was an open section, it would appear hollow when surface modeled. As a closed section, it would be surface modeled with an end plate over the end nearest you. For this model we do not care so enter `o`. For overall depth, a positive number expands the model along the positive depth axis, and a negative number expands the model in the negative depth direction. As we mentioned before, a positive depth in the front view (z axis) is into the screen but in the top and side views, the positive depth direction (in the y and x axes respectively) is out of the screen at you. Again you can refer to Figure 3 for details on the 3D workspace. Enter 100 for the overall depth and 3 for the number of cells.

Though it does not look like it, quite a lot has happened. If you would have looked earlier at a side or top view of our 2D rectangle, you would have seen a line. Now you can see views of our 3D box. To look at a rotated view, press `R (/ROTATE/)` and press `i` to view an isometric. By the way, the front view is the reference for rotated views so if you were not in the front view when you pressed `R`, you were before you had a chance to call the isometric. An isometric is a standard type of view that rotates the model from the front 45 degrees to the right and 35.3 degrees up, and

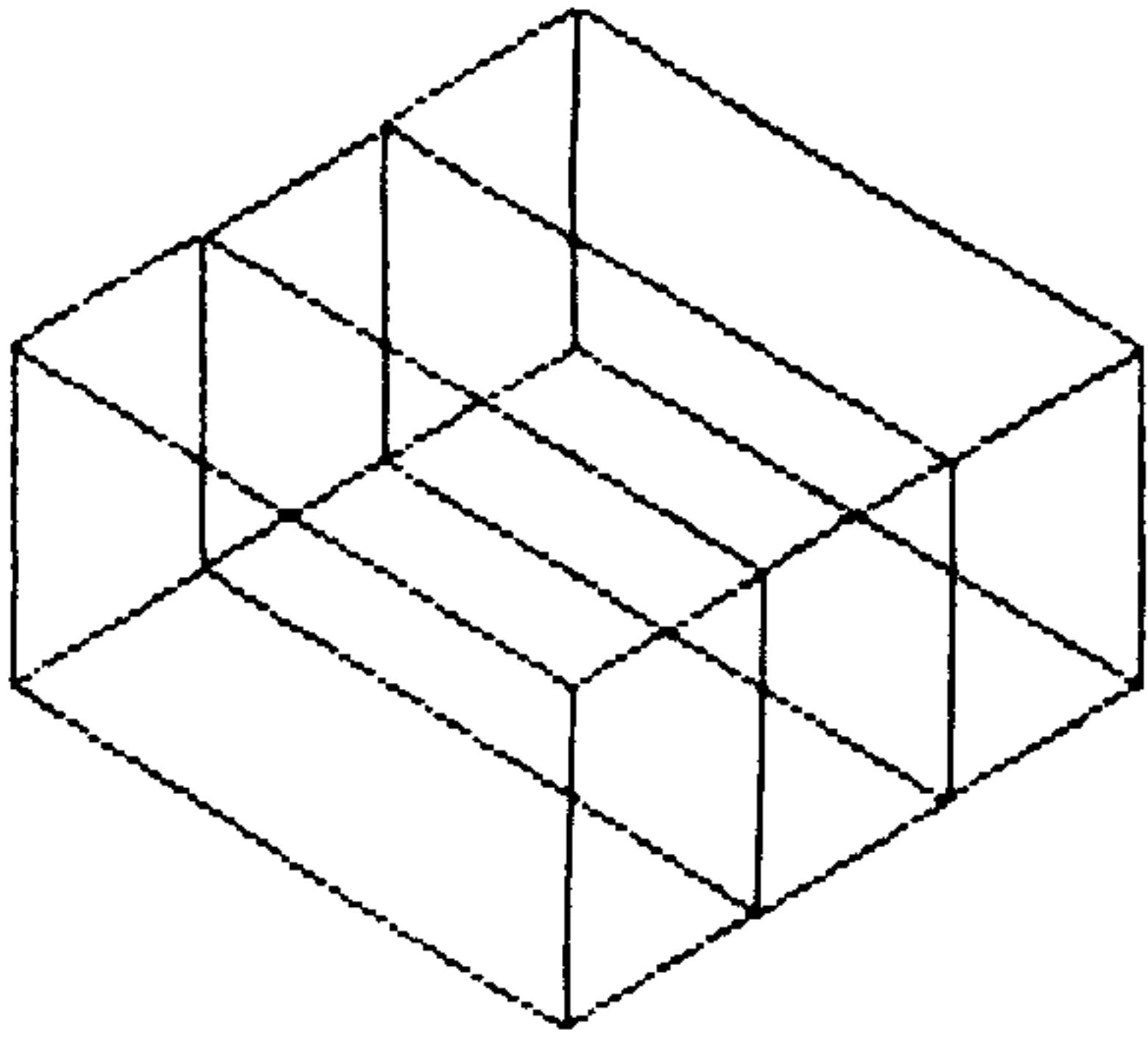

Figure 8

it gives us a better chance to see what we have done. The isometric of the box is shown in Figure 8. This model is called a 3D wireframe model because there are no surfaces displayed or hidden lines removed - just the "wires" that connect the defining points together.

The CELLS command in constant cross section mode is used to expand a 2D drawing into a 3D model. Though it

does not matter what depth plane (z value in the front view) you started with, CONCEPT expects the points and lines that will expand into 3D (like the 2D box made initially in the last example) to all be in the same depth plane. It is not an error to ignore this, in fact at times it may be desirable, but it would be wise to experiment before trying.

The display rotation that we did allowed us to take a better look at our box. If you are still looking at the rotated view, you can see a number of menu items that we have not yet covered. We will discuss them soon (you're welcome to play) but first we need to go on discussing model creation. To get back to the Create Menu, press **r** (/rtn/), then **c** (/create menu/), and **r** (/return/). If you had pressed **m** (/modify/) instead of the last **r**, the rotated view would have become the new front view.

You can see that we have gone through several layers of the program. There are basically three layers; the Create Menu, the Rotation Menu, and the Display Menu. Returning to the Create Menu from the Display Menu (where we were after rotation) requires that we go back through the Rotation Menu in case we wanted to change anything. Just so you are not disoriented.

Cell models - non constant cross section

Now we should be back in the Create Menu with a blank screen. Press **f** to recall the front view. We need to say a few more words about the choice we made when getting into CELLS. We chose a constant cross section model. We will discuss non constant cross

section models now and let you experiment on your own. A model with a non constant cross section will have a shape that varies as you look at an end view. A simple example would be a cone or a vase, but most objects have a varying cross section.

Start a model, window around to some clear space, and draw a 2D figure. Keep track of how many points are in your figure. Press C then n when asked about cross sections. CONCEPT makes a note of how many data points are in the 2D figure, asks if you want an open or closed model (your choice), and then returns you to the Create Menu.

Let's borrow a nautical/aeronautical term and call the 2D figure a bulkhead. As long as you are in this model, you can draw more bulkheads of any shape or size in different depth planes with only 2 rules. The first rule is that each bulkhead must be made up of the same number of points and lines; so if your first bulkhead is made of a point and 7 lines, all others must be too. This is because CONCEPT will automatically connect sequential coordinates of each bulkhead together each time the model is redrawn. Unless all bulkheads have the same number of coordinates, some of the connecting lines will have nowhere to go. Which leads us to rule number 2: all bulkheads must be drawn in the same direction (clockwise, counterclockwise, or at least in the same pattern as the first) unless you are dabbling in abstract computer art. The connecting lines are drawn to connect first through last coordinates in each bulkhead. Within those rules any shape, size, open, or closed section can be drawn at each depth plane.

Mixing types

Within a model you can mix constant and non-constant cross section cell types; just remember the rules above. For example if your first cell model was non-constant and you called **CELLS** to create a constant cross section area in the model, the last bulkhead drawn before calling **CELLS** would be the one expanded. If you then wanted to add an additional non-constant area in the model, you could simply keep drawing more bulkheads in new depth planes.

If you want to preview what the connecting lines will look like in your model, just press the first letter of the view you are in and the view will be redrawn with connectors. Remember that all bulkheads are stored and drawn sequentially. If your bulkheads are progressing down the positive z axis for example, and you reverse direction to draw the next bulkhead, your model will fold back on itself. Sometimes that is

exactly what you want, but just in case, in the section on model manipulation we will discuss how to move and rescale bulkheads within a model.

By the way there is no penalty for rotating your partially completed model to have a look at it as we have done before. Just remember to check that your depth plane did not change when you return to the Create Menu. Have fun experimenting!

File handling

If you have been experimenting with 3D cell models, you probably have something created that you want to save. CONCEPT saves and loads models to and from any mass storage device. You can also merge models stored on a device with those in memory if there is enough room. It is a good idea to save models occasionally while you are creating them just in case you change your mind about something you did, or in case the power goes out.

To get into the files area, press **F** from the Create Menu. Saving a set of models is fairly self explanatory, just follow the prompts. All models in the computer are saved at once on the active drive. The active drive when the program is loaded is MDV2, but using the **drive** command, you can change the active drive by entering MDV1, or the code for floppy disks, hard disks, or RAM drive. You do not need to type the underline at the end of the drive abbreviation; CONCEPT will put it there for you. If nothing happens when you save, load, or merge models, then there is something wrong with the active drive. You may have forgotten to put in a disk or cartridge, or the wrong drive may be active. When you call **drive**, the current active drive is displayed in parenthesis.

File naming convention is standard per the QL User Manual. If a file with the entered name already exists, CONCEPT will ask you if you want to overwrite it. If you key 'n', the files menu will come back up so you can rename your file.

Cat displays a catalog of files on the media in the active drive, just like DIR in Qdos. Each CONCEPT file is stored as 2 files; one with a **_cd** extension (coordinates) and one with an **_md** extension (models). When you want to **load** a file, only type the name of the file you want, not the extensions. Any load error causing the file not to be found will send you back to the file name prompt to try again. To get out of the file name prompt, press **ENTER** and you are returned to the file handling menu. Do not remove the cartridge until after the loaded models are drawn and it has stopped spinning.

File merging works just like loading except that the models being merged are located relative to the current cursor position. No matter where the models were positioned when they were originally created, when they come in to be merged, the start point of the first model of the merged set will be at the current cursor position, and the screen will be centered about that

position. This is done to keep models from merging on top of existing models; that would not hurt anything, it would just be inconvenient if you did not want them to be there. It is a good idea before merging models into an existing set of models, to save the existing set. That way if you do not like the position of the merged models, you can reload the original ones and try the merge again at a new cursor position.

If there is not enough room for all of the merged models, none of them will be loaded and you will return to the point where you were before you tried to merge. The one exception is that if there is room for all of the models, but both the models in memory and those to be merged have text within them, and the total number of notes is greater than 20 (the maximum you can have in memory at one time), then some of the notes in the file being merged will not be loaded.

Erase is used to remove CONCEPT data files from the active drive. Since the command could be used to inadvertently remove data, it should be used with care.

To use the command, press e from the FILES section. You are asked to input the file name of the CONCEPT model file that you want to delete. Do not include the _cd or _md extensions; the files will not be recognized, and CONCEPT adds the extensions automatically when deleting. Once the file name is entered, the files are deleted and you are returned to the FILES menu. If the file name is not found, you are notified and returned to the FILES menu to try again.

More 3D modeling

Surfaces of revolution

In this type of model a series of lines are drawn and then swept around a horizontal axis line to create a cylindrical model. The best way to learn how to do one is to try an example. It does not matter which view we start with, but just for consistency, let's get into the side view since a surface of revolution looks most like a side view relative to what we have been doing. Window away from any other models on the screen and start a new model. Press **S** (/SURF REV/) and **ENTER** for a fully circular model. We will do a partial rotation later. A dotted horizontal axis line going through the cursor should be on the screen. Let's create a wine glass.

Draw lines representing the edge of the glass like those in Figure 9 (we have highlighted the coordinate points). Don't forget to start with a point. The model will be constructed just like the cell model created in the section on cells, but instead of drawing a bulkhead, we have drawn one set of the lines that will connect the bulkheads together. Each coordinate is a point on a bulkhead. We can call this group of lines a section. Now it is time to let the QL take over. Press **S** again and after a short pause you should be looking at the side view of the wine glass (Figure 10). Since wine glasses are usually open at the top, enter **o** for open section when prompted. If you did not want a wine glass laying down, you would be able to use the techniques in the Model Manipulation section to move and rotate the model where you wanted it.

If you try to get into another view while in the middle of drawing the defining section of a surface of revolution,

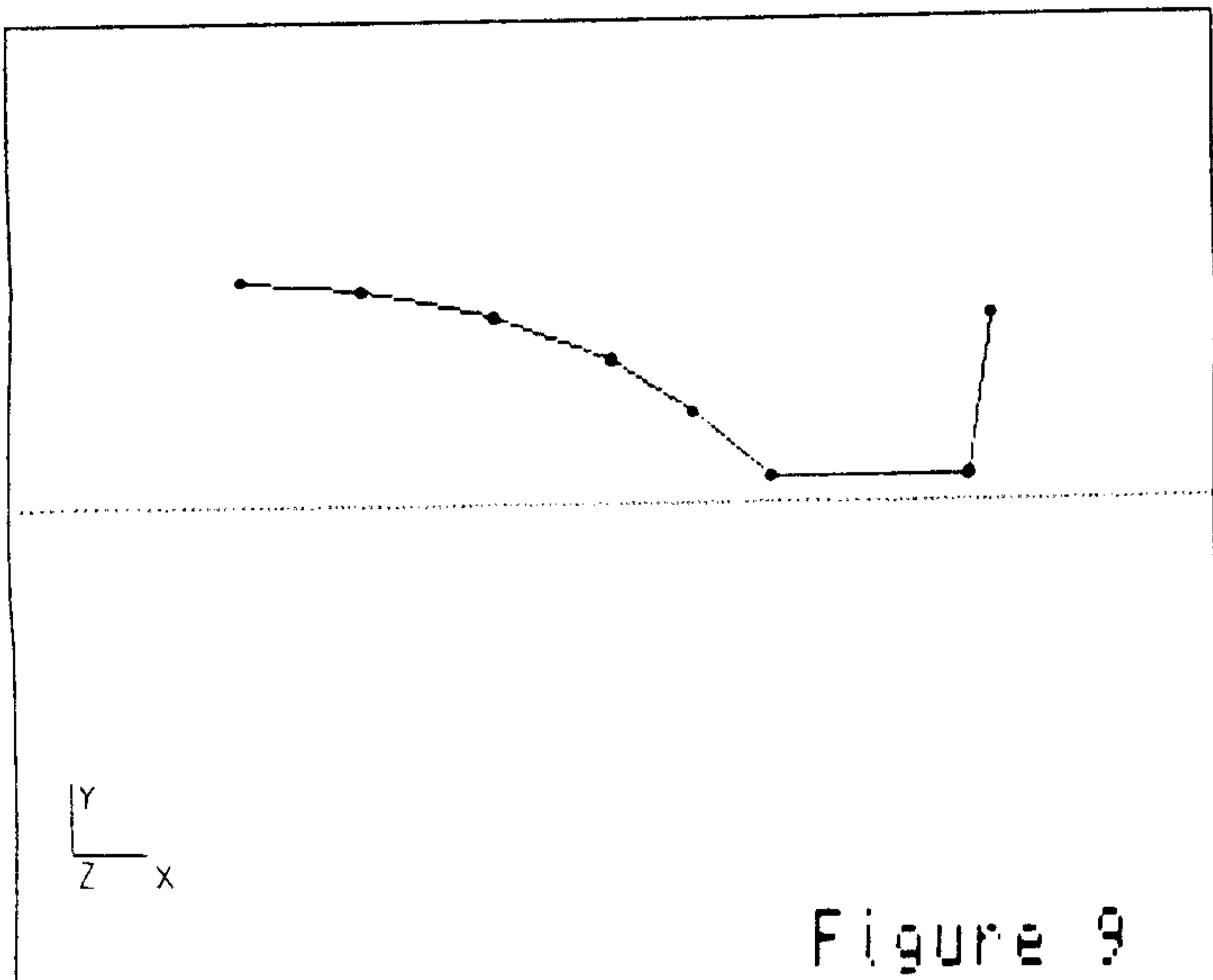

section. Now it is time to let the QL take over. Press **S** again and after a short pause you should be looking at the side view of the wine glass (Figure 10).

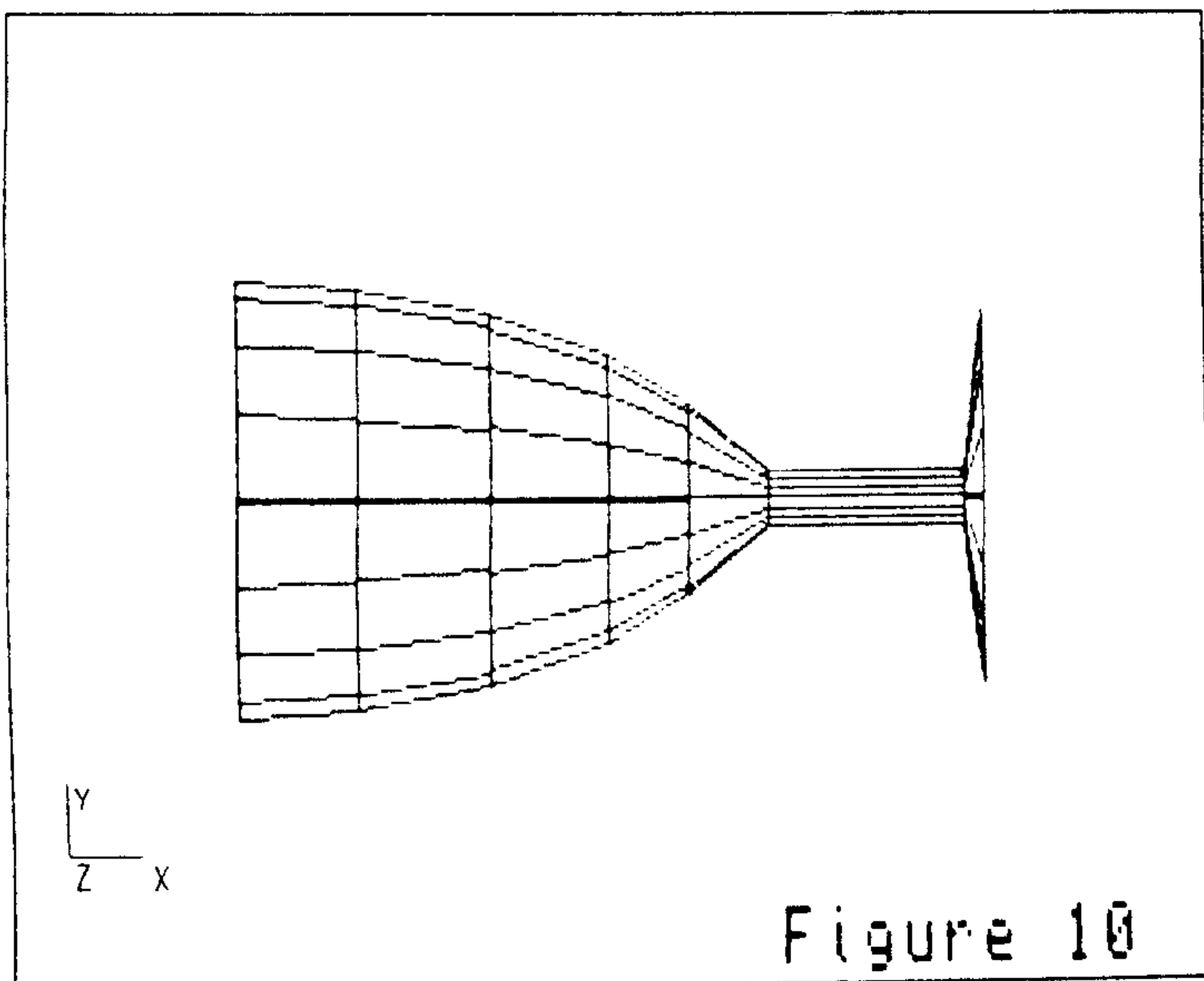

you will find that CONCEPT will not let you. This is the only type of model that will not allow you to change views in the middle of the creation process. You can however, change window position and viewing scale factor as often as you like. Many times you will probably need to so you can complete a section that is running off the screen.

Now you can look at an isometric view of the glass like we did before; press R to rotate and i for an isometric. This model only represents a surface of revolution. It is really a collection of lines that define where surfaces are meant to be. This is true of all CONCEPT models.

A sphere is an interesting model to make. Press S and ENTER as before, and place a circle right on the axis line. If you rotate this section 360 degrees, you end up with 2 spheres on top of each other, so use F4 to erase the bottom half of it. Now press S to complete the sphere.

Partial revolution

A large number of objects can be modeled as surfaces of revolution. Let's look for example at the

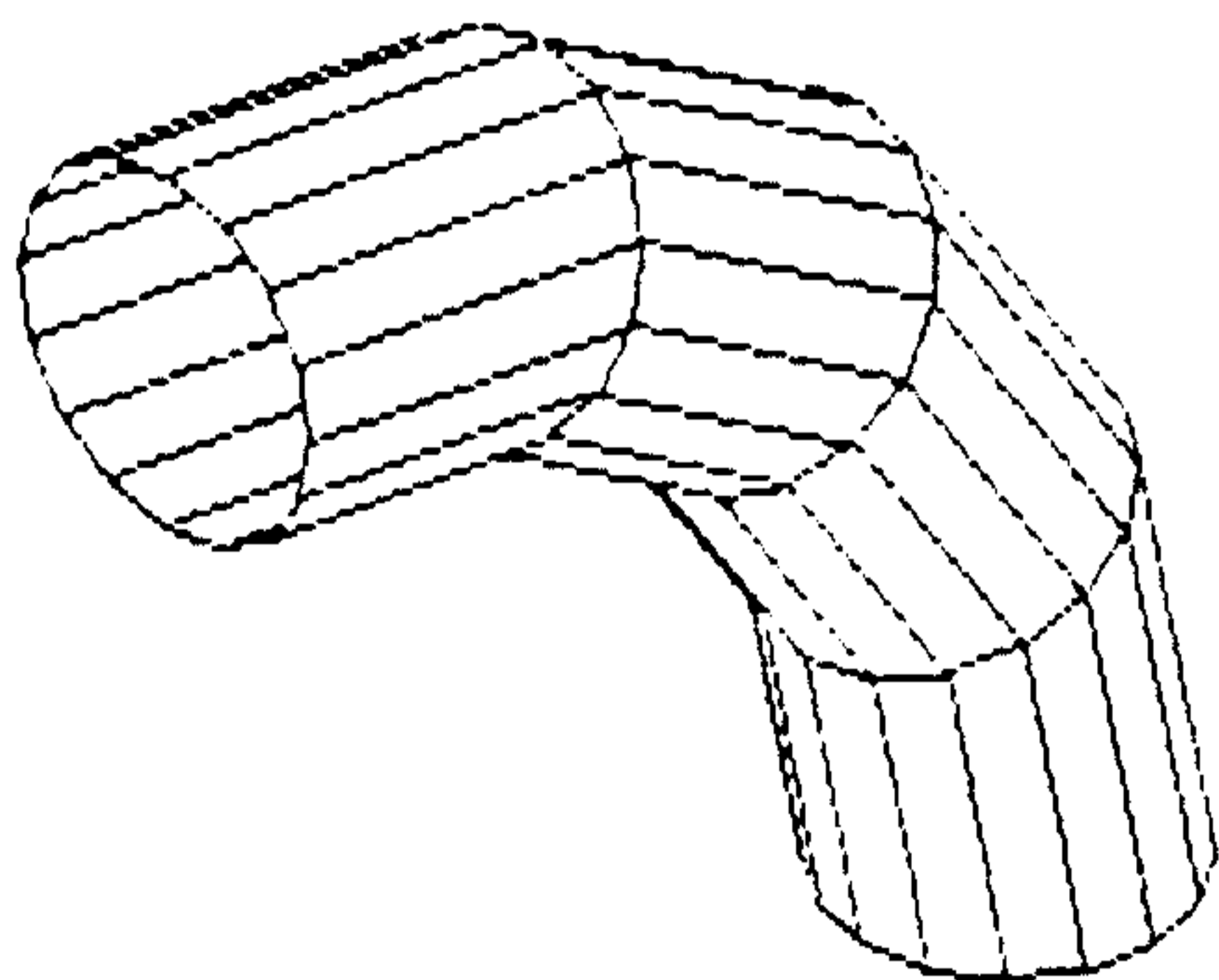

Figure 11

pipe bent 90 degrees in Figure 11. How would we model that? It is done in the same way as the wine glass except the section is swept 1/4 of the way around. Return to the Create Menu, find some open space and start a new model. You have 50 models available so there is almost never a penalty for using a lot of models. Press S for a surface of revolution and enter 90 degrees this time for a 1/4 revolution. Place a circle somewhere

above the axis (or below if you want) and press S again to complete the model.

Any angle of revolution can be specified; the program adjusts its bulkheads and connectors accordingly.

When sweeping a circular or other closed section into a surface of revolution, the resulting model is

usually open ended so key an o at the prompt. The bulkhead "end" appears to be the circular portion of the pipe, but in reality the bulkheads are the lines rotating around the axis line; in this case they are a series of 90 degree arcs. If you wanted to have the end of the pipe closed off when later surfacing the model, you could create a separate single celled, 0 depth, closed ended cell model of the same diameter as the pipe and place it over the end.

Now try creating a "partial" sphere.

Before we go on, we need to talk some more about circles and ellipses. We mentioned earlier about tilted

ellipses and the need for occasionally specifying the angle of tilt on circles. Take a look at Figure 12. The right hand figure is made from the left hand section: 2 lines and a 90 degree radius. If we start a circle with a 90 degree tilt and remember that circles are drawn counterclockwise, we can use **F4** to remove 3/4 of the circle and end up with the arc we want. So you would draw a horizontal line from right to left, move the

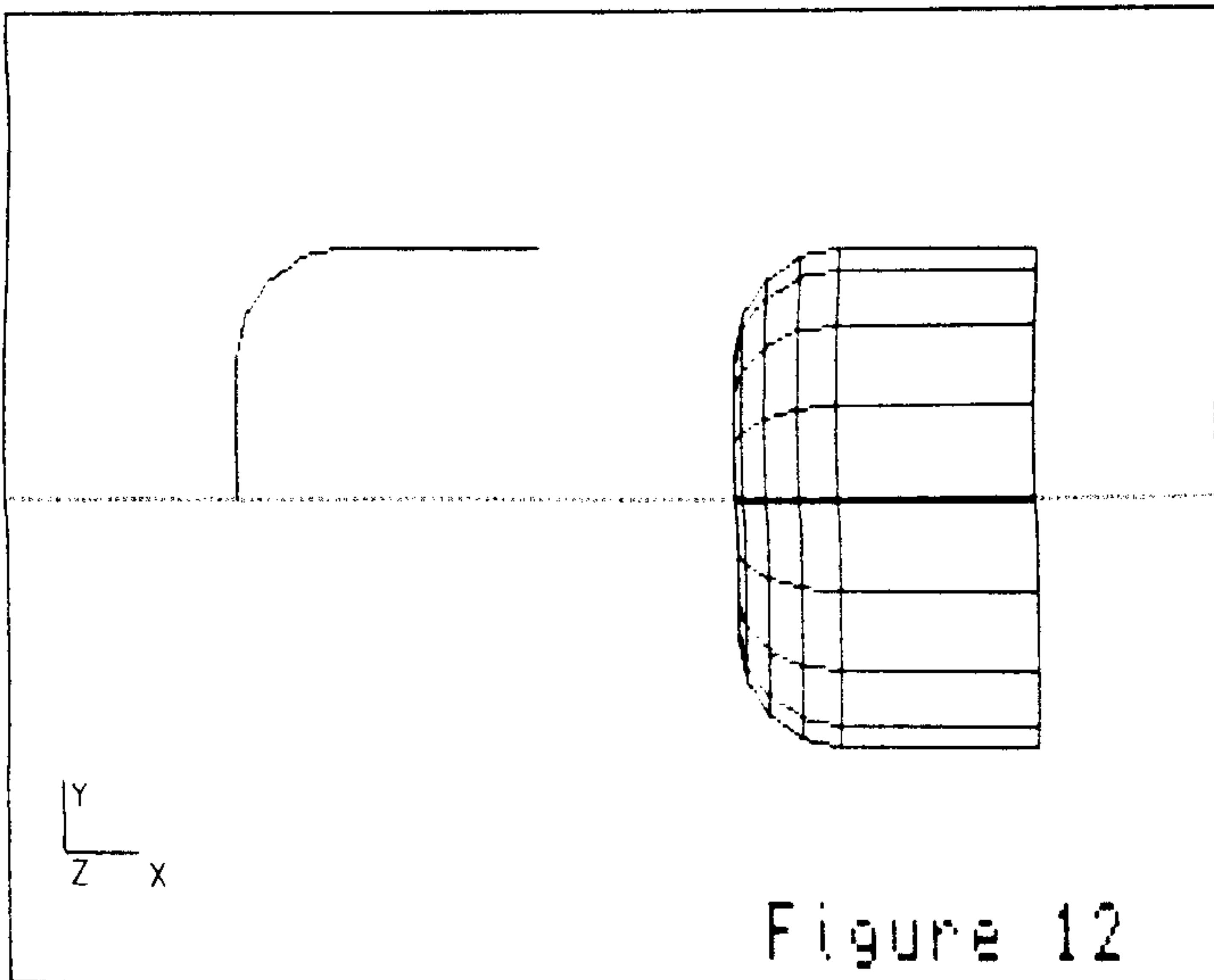

Figure 12

cursor down however much the radius will be, make a circle of the appropriate diameter at 90 degree tilt so we start where the line left off, use **F4** until 1/4 of the circle is left, then move the cursor directly below the dangling end of the radius and draw a vertical line down.

3D free form drawing

Free-form drawing simply means placing points and lines anywhere you want in 3D space. By using front, top, and side views and rotation of the model or models, you can visualize what you are working on.

The only restriction on free-form drawing is that the resulting model cannot be displayed as a surface model. In order to "surface" a model, CONCEPT needs to have model data in a certain format. There is no consistent format for free-form drawing so when a series of other types of models are being surfaced, any free-form models will be drawn as wireframes.

Remember to start a new model after creating a free-form model and before keying **CELLS** or **SURF REV**. If you do not, when you try to surface model everything, the surfacing routine will try (and fail) to surface the free-form portion of the model.

The Rotation Menu

So far we have done some isometric rotation of models to visualize our model creation, but now it is time to delve into the subject a little more deeply. The Rotation Menu includes commands for 3 axis rotation and for isometric rotation, which is a standard view used by drafters and graphic artists.

When you press R from the Create Menu, CONCEPT puts you into the front view if you are not already there. All models are rotated the specified number of degrees from the front view in 1, 2, or 3 axes, and they are rotated about the $x=0$, $y=0$, $z=0$ point; that is the pivot point, and the rotated view is centered about that point. After rotating, you are in the Display Menu area and can window in, out, and around.

In 3 axis rotation, the sequence of rotations determines the final orientation of the models. In CONCEPT, we chose to rotate first about the y axis, then the x axis, and finally the z axis using the front view as a starting point. Of course if you choose to rotate about only 1 axis, that is what you will get, but if you rotate about 2 or 3, the priority is y, then x, then z.

The reference axes in the lower left corner, point in the direction that the models have been rotated; you undoubtedly saw that in our earlier isometrics. Again, red axes run into the screen and green run out at you or are parallel to the screen. The axes of rotation do not vary. They are the front view axes: x horizontal, y vertical, and z into and out of the screen. So for example, in an isometric, the models are rotated 45 degrees to the right (about the vertical y rotation axis), then the resulting view is rotated up (about the horizontal x rotation axis) 35.3 degrees. Then the screen is redrawn.

We are looking at a lot of information here and it is about time for an example, but we have one more subject to cover: direction of rotation. Here again the direction of rotation is either positive or negative. CONCEPT uses the right hand rule to determine positive and negative rotation. If you hold your right hand up with your thumb pointing in the direction of the

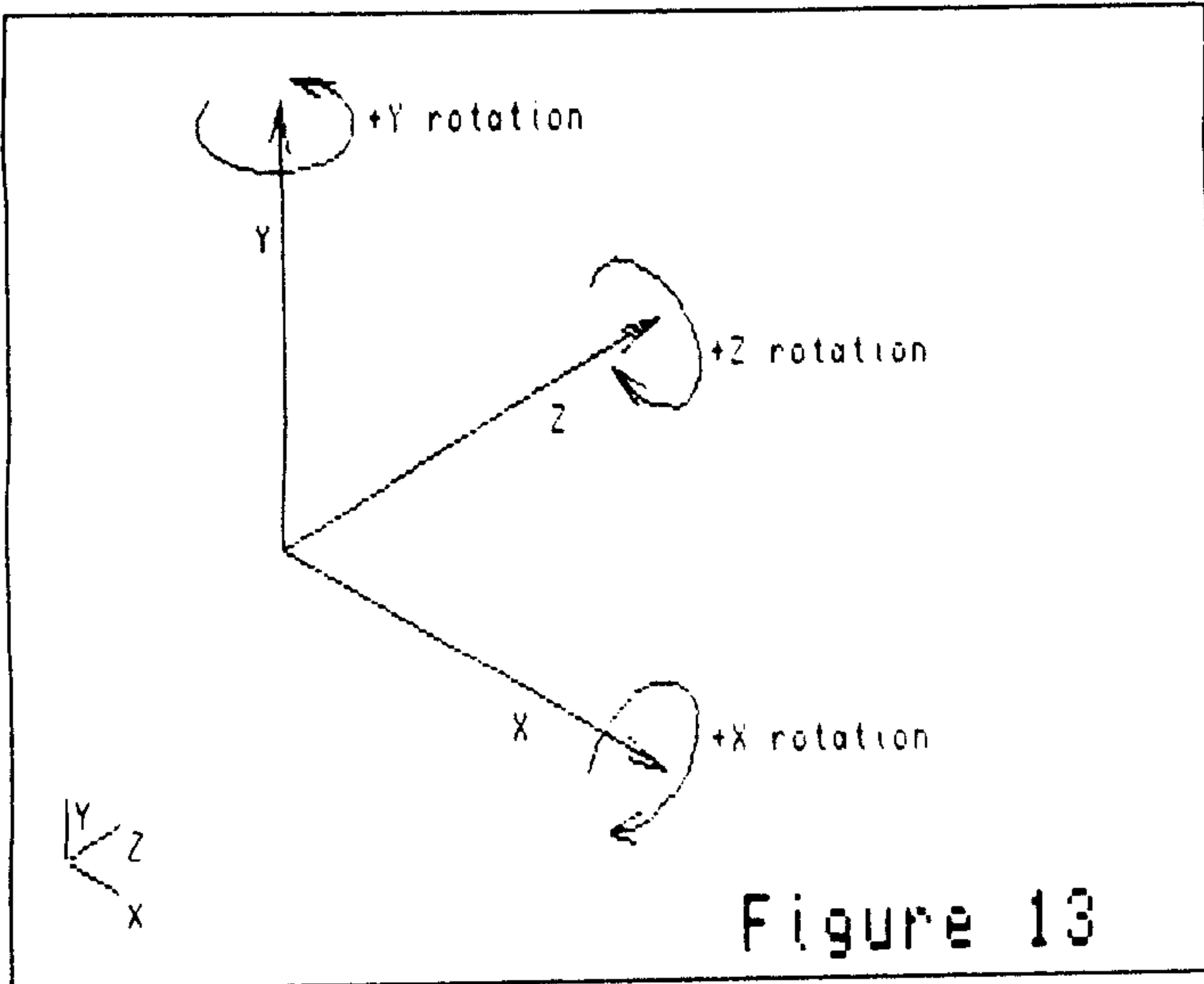

Figure 13

positive axis, you fingers curl in the direction of positive rotation. Figure 13 shows a view of the rotation axes. You are forgiven if you hold your hand up and wave your thumb around when starting to rotate; we do it all the time. If anyone catches you at it have them read this page.

Enough theory, let's get on with an example. We will use the 3 celled rectangular

box that we created in the section on cell modeling. First we will do an isometric but we will do it the "long" way. Press **R** from the create menu, then **r** (**rotate/**). Angles about axes are entered in the same order as the box will be rotated. Rotation about the y axis is negative because the portion of the box that is furthest away moves to the right, so enter -45 degrees. X axis rotation is positive since the back of the box is moving up, so enter 35.3 degrees. There is no rotation about z so just press **ENTER**. The rotated view should look like Figure 14.

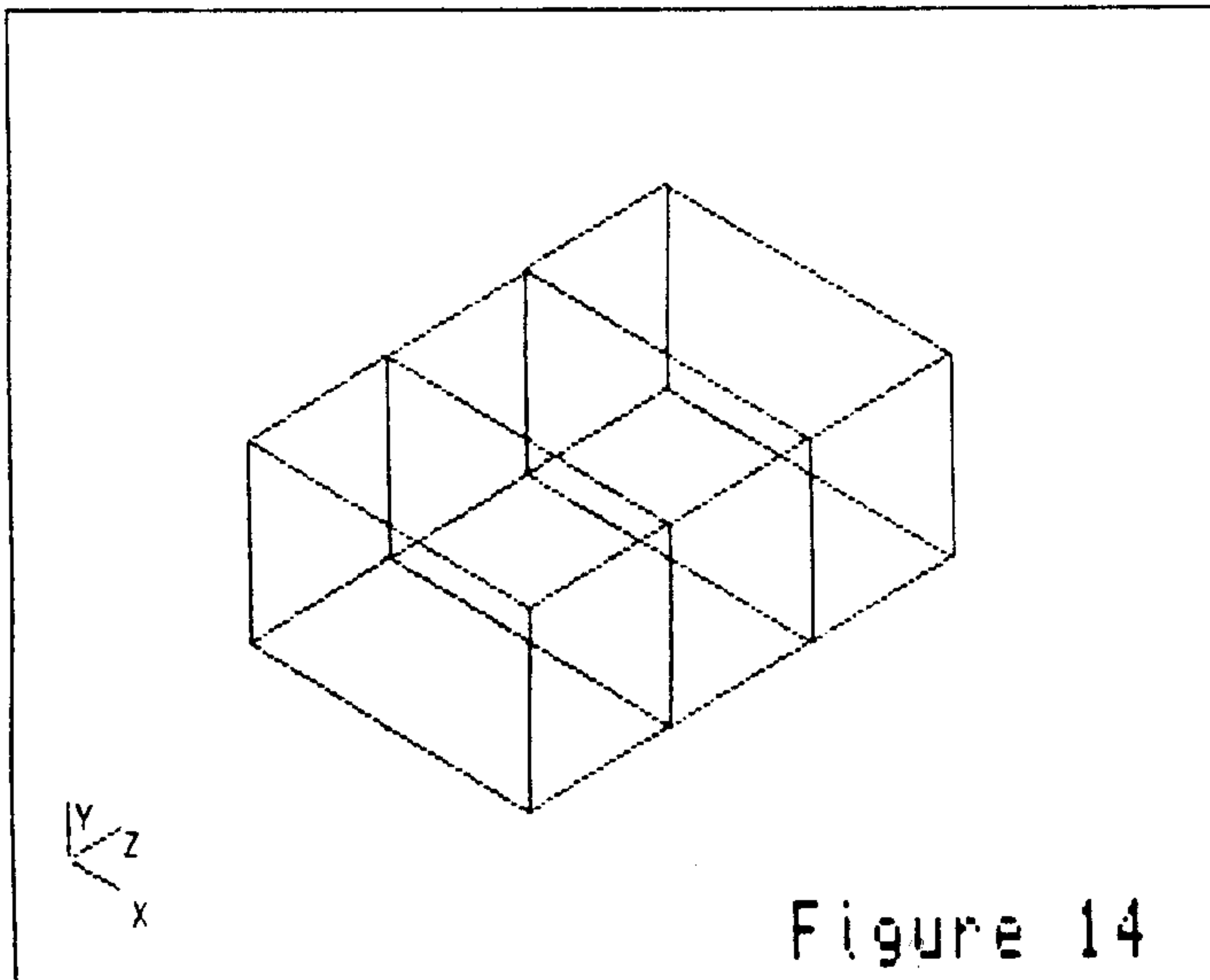

Figure 14

Successive rotations are not additive, they always start with the base front view geometry. In other words if you rotate models 45 degrees in the z axis and then return and rotate them 45 degrees in z again, you will end up with a 45 degree rotation, not 90.

As we have mentioned before, rotating puts **CONCEPT** into the Display Menu area. To return to the Rotation Menu press **r** (**/rtn**). To get back to the Create Menu, press **c** (**/create menu**) and **r** to return, or **m** (**modify/**) to change the front view into the rotated view and return.

The Display Menu

The Display Menu contains commands to view in perspective, remove hidden lines and surfaces, put notes on your drawing, and dump the screen to a printer. There are 2 ways to get into the Display Menu. The first is through the Rotation Menu as we mentioned before. The second way is to press D (in caps) from the Create Menu if you do not want to rotate a model. The front view is the base view for the Display Menu so if you are not in the front view when you press D, CONCEPT puts you there just as it does when going through the Rotation Menu. When returning to the Create Menu, you will go through the Rotation Menu.

Perspective

Perspective is used along with windowing to look at the models from a realistic viewpoint. Without perspective, models are projected onto the screen without regard to the effects of their distance from the screen. This is essential for creating models, but it is not realistic. Viewing in perspective also helps in visualizing the orientation of wireframe models.

CONCEPT's perspective acts on all models at once and uses the center of the screen as a vanishing point. The further into the screen that an element of a model is, the more it moves toward the vanishing point.

Let's do an example of an end view of 2 parallel lines. Start a model in the front view and place a point at $x=50$, $y=0$, $z=0$. Then draw a line to $z=5000$ with the same x and y position. Do the same at $x=-50$. Remember to reset z equal to 0 for the point and to 5000 for the line. You should be looking at 2 points on the screen. Now go to the display menu by pressing D. If you window around without perspective on, the 2 points simply move around the screen. Now press p (/persp/) and enter 200 for an eyepoint position. The eyepoint value is displayed in white on the top line. We are working in pixels again here and the most realistic views can be had using an eyepoint position value that is a rough guess of how many pixels your eye is away from the monitor screen in window 1, or full viewing scale. Now when you window around, the 2 lines point to the vanishing point.

Imagine yourself standing on railroad tracks. As you look down the tracks, they seem to run together a long distance away. If you imagine yourself stepping off to one side of the tracks, they still run together at the same vanishing point; it does not move even though you have. You can duplicate this by windowing

with the cursor directly over and between the starting points of the lines and then windowing with the cursor moved slightly to the left or right.

The demo in perspective

Now let's view the sailplane demo in perspective. Load the demo and display it as an isometric. Enter a perspective eyepoint of 200 again. You can see the effects of perspective on the sailplane. The eyepoint value that you entered is measured to the coordinate point that is nearest to you; in this case, the end of the left wing. So the view is as if you were standing 200 "pixels" away from the left wing.

Perspective windows

Now enter 50 for a perspective eyepoint value. The perspective is much more exaggerated. As you window out, say from 1 to 2, the plane will obviously get smaller, and the eyepoint position you entered will be multiplied by the window factor just as if you were moving away. So in this case we were standing 50 units away from the wing tip in window 1 and now in window 2 we are standing 100 units away.

To show another aspect of windowing with perspective, go back to window 1, return to the Rotation Menu, and enter 10

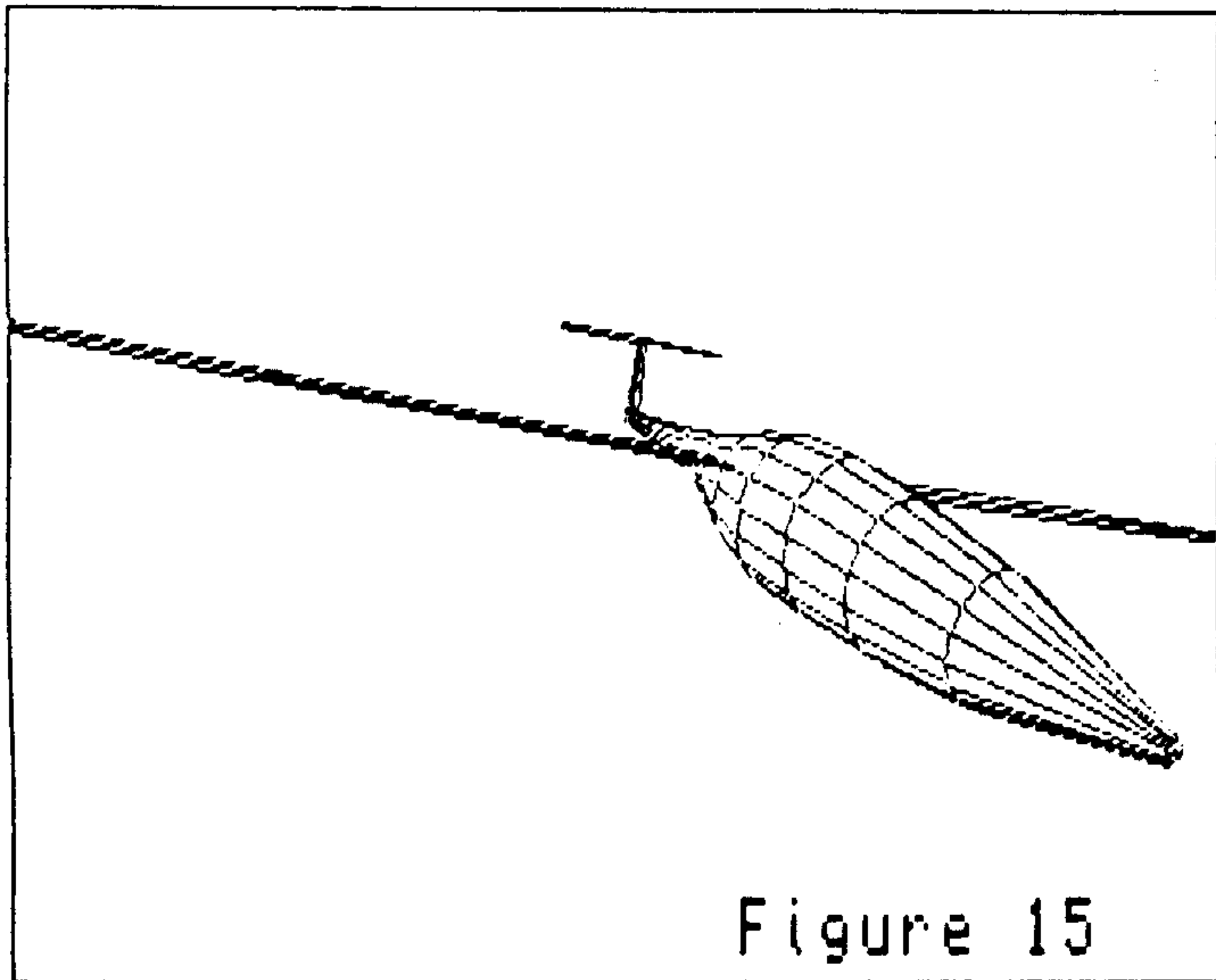

degrees for each of the 3 rotation axes. Now we are looking at an almost head-on view of our sailplane still in perspective. The only way to eliminate perspective by the way is to enter 0 for an eyepoint value or return to the Create Menu. Now move the cursor a ways to the left and window leaving the window factor at 1. The screen should look something like Figure 15, as if you were standing to the

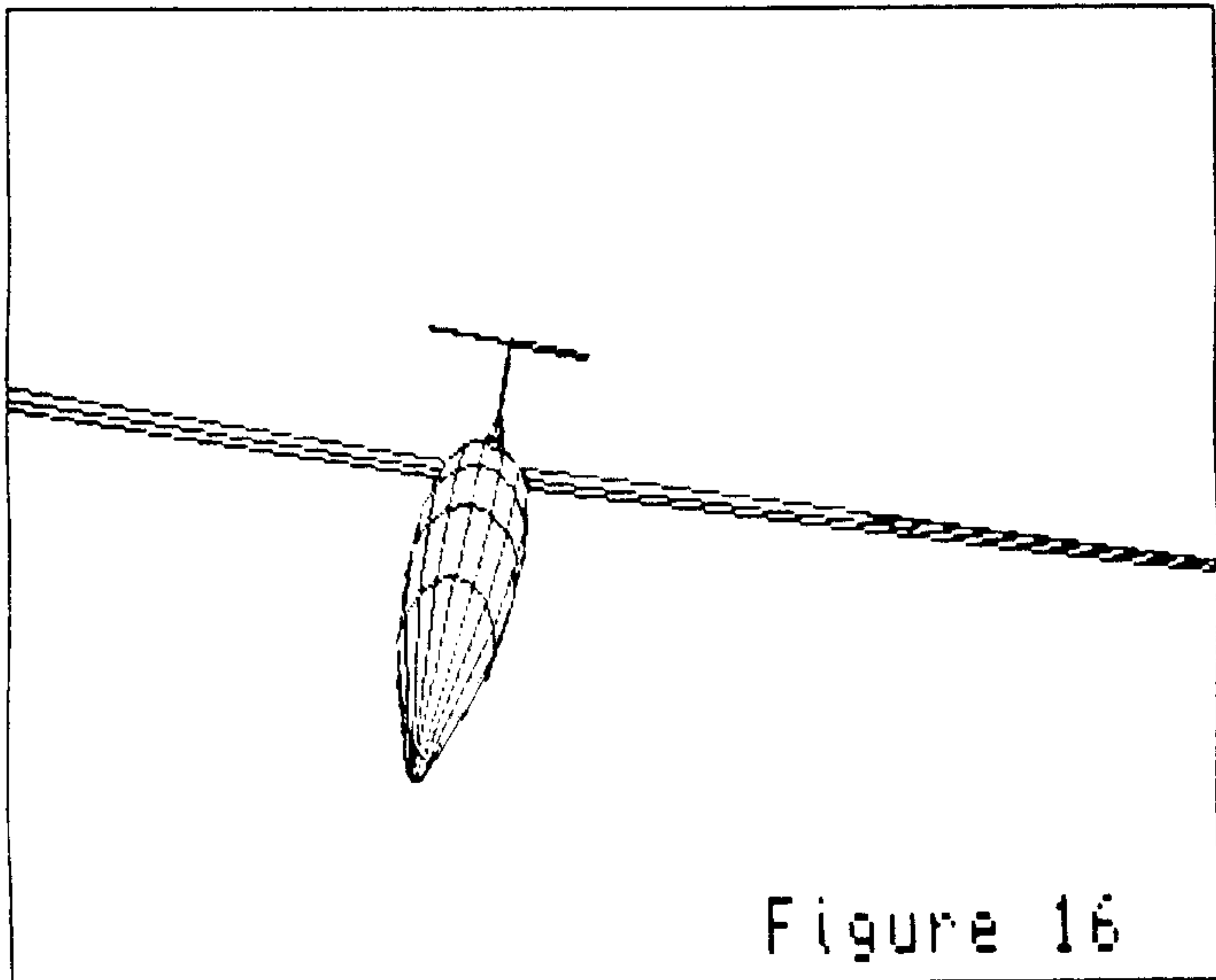

Figure 16

left of the aircraft. Now move the cursor to the right and window. You should see something like Figure 16. The center of the screen is the vanishing point and by moving the screen around as we do with the window command, it is as if we were walking around in front of the aircraft.

Surface modeling

The surface (/surf/) command in CONCEPT is completely automatic;

all you need to do once you are happy with the way things look in the Display Menu is to press **s**.

What CONCEPT does then is to sort all of the models, putting them in order starting with the furthest away and ending with the nearest. It then does the same thing to the panels in each model when it is the model's turn to be surfaced. Each rectangle that makes up the model is filled with model color and bordered with either white or black depending on what the background color is. Each model is surfaced in turn from back to front.

The type of surfacing routine CONCEPT uses is well suited to the unexpanded QL since it does not require a great deal of memory, but it is not a perfect surfacing routine. Some model shapes and configurations can not be properly surfaced automatically, but there is almost always a way to make everything work out either by using override which we will discuss shortly, or by using the techniques presented in the Using CONCEPT 3D chapter of this manual. If something does not look right for any reason while surfacing, press ENTER to escape.

As we mentioned in the free-form 3D drawing section, only cell models or surfaces of revolution can be surface modeled by CONCEPT. However, free-form models are sorted along with all of the other models, and they are drawn as wireframes when it is their turn to be drawn.

Line modeling

Line modeling is started, as you must be able to guess by now, by pressing **l**. Everything we have just discussed on surface modeling also holds true for line

modeling, except that rectangles are filled with the background color and bordered by the model color. You then have a wireframe drawing with hidden line removal. Again, if something does not look right, press ENTER to escape.

Override

CONCEPT'S automatic surfacing averages the z value of each coordinate in each model to obtain a number which represents the depth of the center point or centroid of the model. These numbers are then sorted and surfacing is started with the model whose centroid is furthest into the screen, and ended with the model whose centroid is nearest the viewer. Problems can come up here when a model is much larger than its neighboring models. A large model may have a centroid closer to the viewer than a smaller model that is actually in front of it.

Figure 17 shows 2 wireframe cylinders. The smaller one is actually in front of the larger one but it is easy to see that the center point (which can be thought of as the balance point) of the larger cylinder is closer to the viewer than that of the smaller one in this particular orientation.

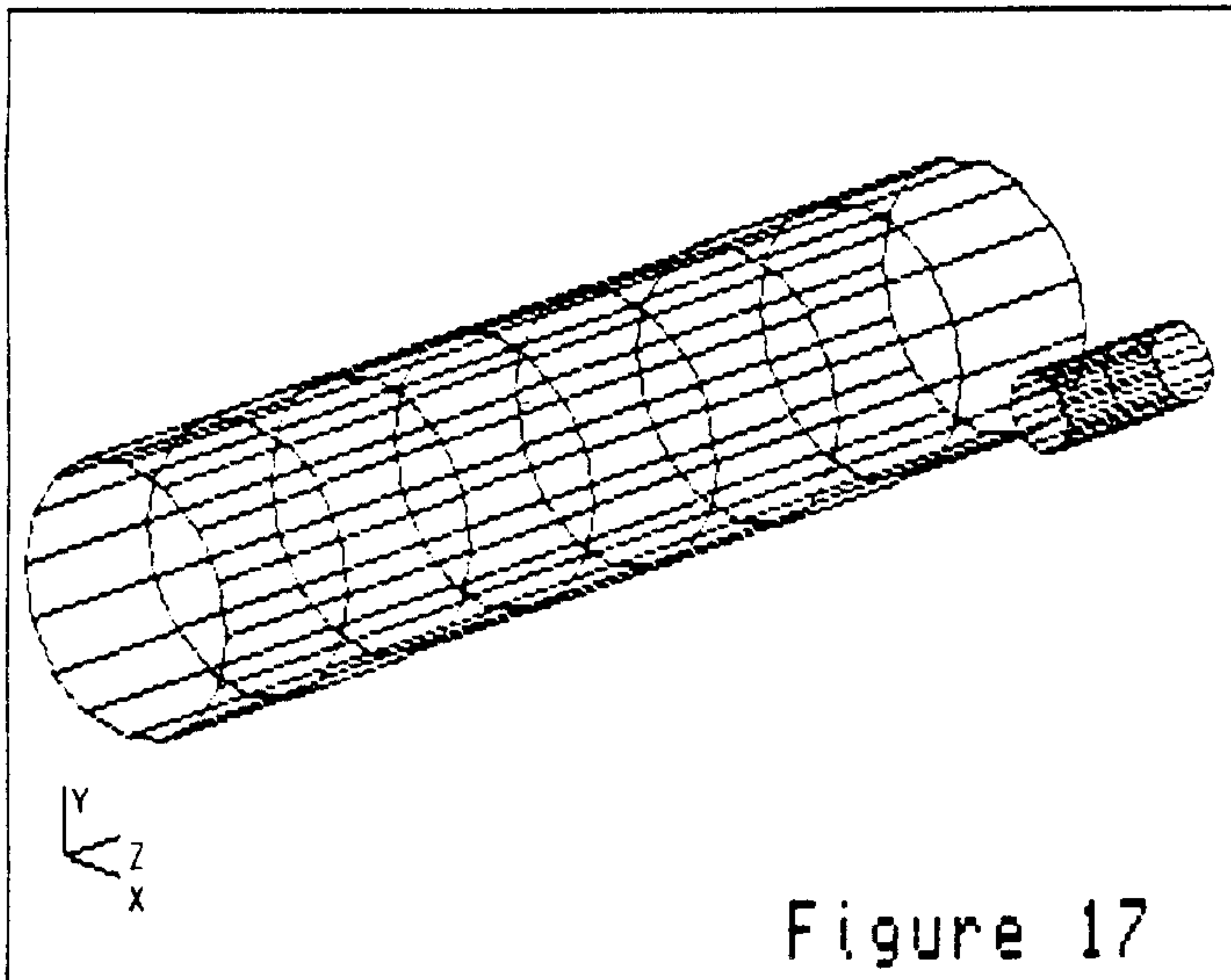

Automatic surfacing comes out like Figure 18 which is incorrect.

Keying the override command (/o'ride/) and then keying it again at the **override/reset**

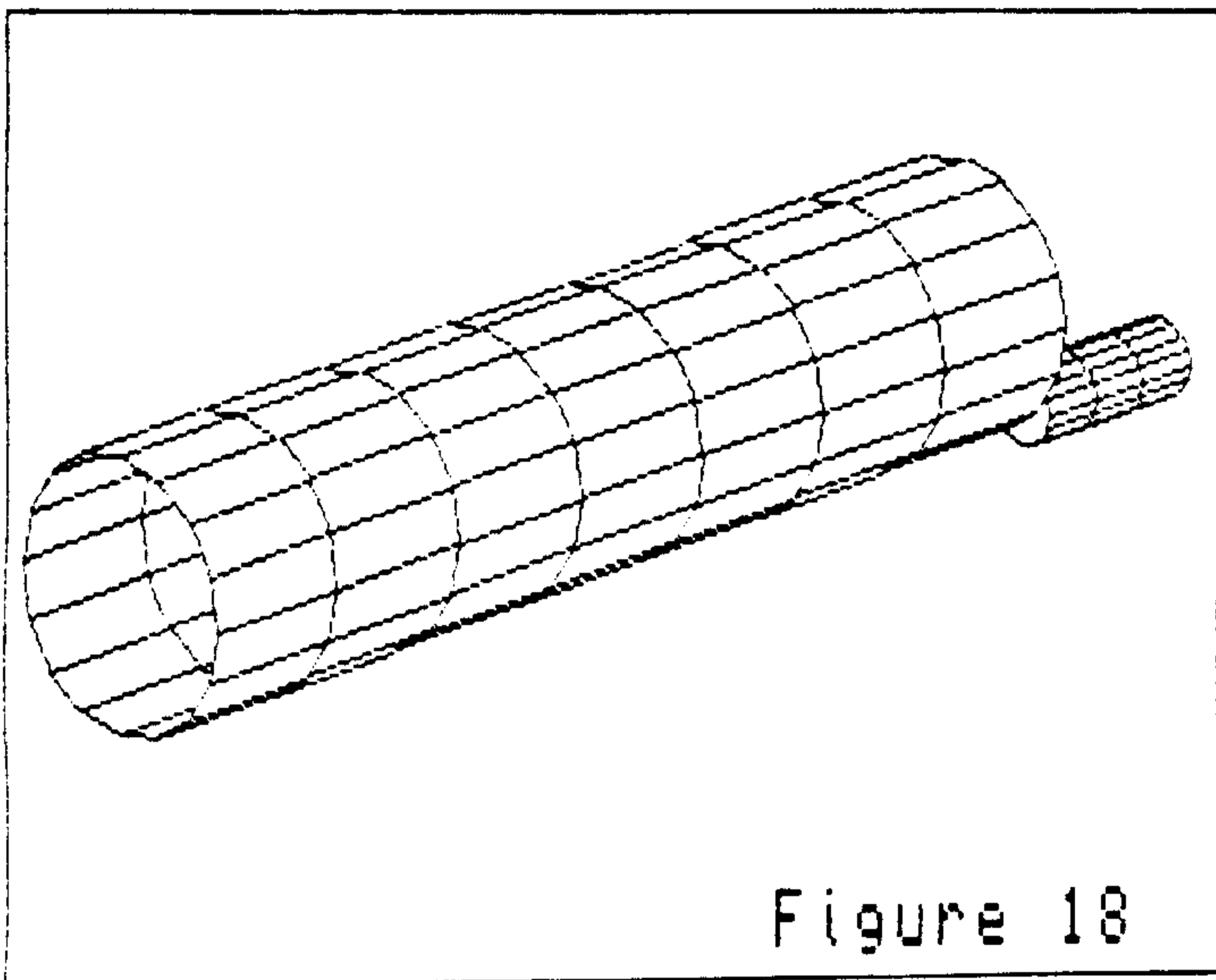

Figure 18

cylinder is keyed in similarly. CONCEPT asks for these priority numbers for every model displayed. Key model numbers in the order you want them surfaced; when all of the models have been keyed in, you are returned to the Display Menu. Figure 19 shows the cylinders surfaced

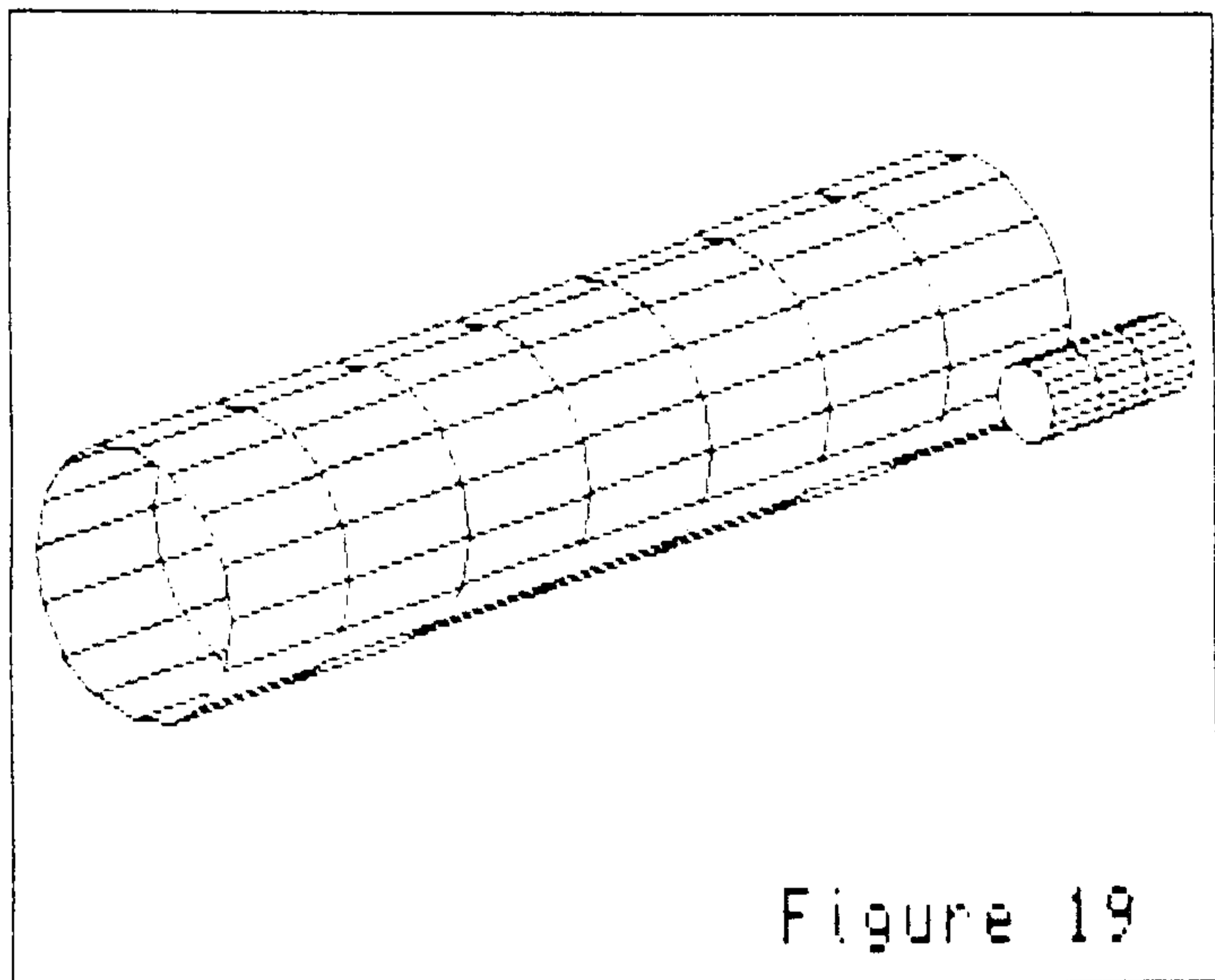

Figure 19

prompt allows you to change the priority that CONCEPT uses to surface the cylinders. Model numbers are displayed for reference next to the start point of each model, and you are asked to enter model #1. Model #1 is the model which you want to have surfaced first; in our case, the larger cylinder. The number of the larger cylinder is keyed in and its displayed number is blanked out. Then the number of the smaller cylinder is keyed in similarly. CONCEPT asks for these priority numbers for every model displayed. Key model numbers in the order you want them surfaced; when all of the models have been keyed in, you are returned to the Display Menu. Figure 19 shows the cylinders surfaced correctly after using override to change the priority.

The new priority stays in effect until **reset** is used. The next surface modeling after keying reset is done using the automatic priority. To reset to automatic surfacing, press **o** from the display menu and **r** to reset. If a model is added to or deleted from the set of models, a reset is done automatically.

Text

Keying **t** from the Display Menu allows you to place notes anywhere on the screen. 20 notes are available and each one can have a maximum of 34 characters. You have a choice of 5 character sizes and all single digit colors. Text is saved, loaded, and merged as a part of the model file.

After keying **t**, you will then see an **input/change/delete/return** choice. Press **i** to input a note. The brackets on the input line show the 34 character maximum length. Enter some text, then enter a

Text size 1

Text size 2

Text size 3

Text size 4

Text size 5

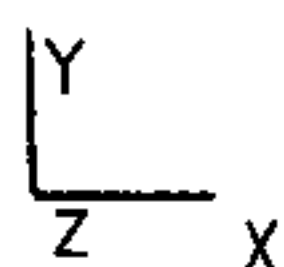

Figure 20

color number and a character size. Figure 20 shows the relative sizes of the text. Once size is entered, the note is displayed on the screen with the cursor at the upper left corner of the first character. To place additional notes, move the cursor where you want the note and go through the same procedure.

To change a note in any way, press **c** at the **input/change/delete/return** choice that comes

after each note is entered. Now if you press **(shift)<** or **(shift)>**, the cursor will jump to each note (at the upper left corner of the first character) in order. When the cursor is "on" the note you want to change, you have 2 choices. If you want to move the note, use the unshifted cursor keys to move the cursor to the desired position and press **ENTER**. If you want to change the note, press **ENTER** when the cursor is on the note and **CONCEPT** will start the input procedure again. To change the text, just key in the new note. If you only want to change color or character size at this point, press **ENTER** instead of retyping the note.

To delete a note, key **d** with the cursor on the note. The note does not actually go away; it is only blanked out. It can be changed back into a note again by going through the change procedure with the cursor at the point where the note used to be (use shifted **<** **>** keys to get there).

If you do any work on your models after creating notes that causes the screen to redraw, or if you have loaded a file with notes in it, they will not be displayed until you press **t** from the Display Menu. If you change your window factor from what it was when you created the notes, their start points will be scaled with all of the model points, but the size of the notes will not change. Notes are positioned relative to models with **x** and **y** coordinates that the models use, but they are 2 dimensional; their **z** coordinate is 0.

Screen dump

CONCEPT uses the **EASEL** (business graphics) screen dump program to send printouts of the screen to Epson

compatible printers from the Display Menu. Dark and light colors are reversed using the EASEL dump, so the default black background comes out white in the printout. Because you are using a device out of CONCEPT's control (the printer) we suggest you save your drawing before you use the screen dump.

Press **d** (**/dump/**) from the Display Menu, and you are prompted to put the EASEL cartridge in MDV1 and press any key. Once the dump program is loaded, the information and command lines are blanked out and new narrower side borders are displayed. The side borders indicate the width limits of the screen printout. The next prompt is **go/return** so if your models or text extend outside of the narrower borders, you can press **r** to go back to the Display Menu and adjust the display. Pressing **g** starts the screen dump and returns you to the Display Menu with all borders returned to normal.

If you put EASEL in MDV1, press a key, and the EASEL prompt comes back without it loading, either the wrong cartridge was put in or there is something wrong with the EASEL cartridge. CONCEPT only requires the dump program to be loaded the first time you use it; subsequent printouts will go directly to the **go/return** prompt.

Using CONCEPT 3D

Manipulating models

To build assemblies of models, we often need to move and turn them into the position we want. Also you may want a surface of revolution for example, that does not have a horizontal center line. There are four commands in the Create Menu that allow you to place models or parts of models anywhere you wish. The commands are **loc**, **edit**, **relocate**, and **get scale**. Using them you can move, turn, or rescale points, lines, bulkheads, models, or everything on the screen.

Locating points

The 4 commands have one thing in common: they all must find a reference, or pivot point in the model they will work with. All 4 commands start out the same way that the locate command (**/loc/**) does. The locate command finds a point under or near the cursor, and displays the model number that the point resides in along with the x, y, and z coordinates of the point. Remember that a "point" can be a coordinate that originally was entered as a point, or it can be the end point of a line. The way to use **loc** is to put the cursor on the point and press **l**. If the point is anywhere in the boundaries of the "+" then it will be found. Along with the model number and coordinates, some additional prompts are displayed if you are in high resolution mode: **locate/set point/return**. In low res mode there is not enough room for the prompts in the command line, but the commands are still available. The locate command allows you to keep looking through the model or models to find the point you want that may be underneath the one just located. **Set point** sets the cursor position to be on the point most recently located and then returns you to the Create Menu. **Return** gets you back to the Create Menu without resetting the cursor.

Let's try an example. Build a constant cross section cell model in the front view starting from $z=0$ and extending in the positive z direction. Make the cross section a rectangle, and give it a total depth of 90 with 3 cells. Now move the cursor to one of the points and press **l**. The coordinates are displayed with z equal to 0. Now press **l** again and you will see the same x and y coordinates, but z now equals 30. You are searching through the model in the order of its creation looking for points within the xy range of your cursor. The z value of the cursor is still what it was when you started locating, so key **s** to set the cursor on the located point. Now verify that $z=30$ by keying **z**. At

some point if you keep locating, you will get a "not found" message which just means that you have gone off the end of the model. If you need to, you can start locating through the points again by pressing 1.

If the point you chose was the start/finish point of the rectangle, you will get 2 coordinate displays in turn that are the same. The first is the start point and the second is the end point of the bulkhead.

Relocating points

Now let's try changing the position of one of the points in the model. Put the cursor on a point and press **e** (**/edit/**). The point is located and displayed as before, but the prompt in high res mode is **continue/locate/return**. **Continue** means that you found the point you wanted and are ready to edit it. Just as before, **locate** allows you to find another point at that x,y location, and **return** gets you back to the Create Menu if you change your mind.

When you press **continue**, you see a prompt telling you to move the cursor to the new location and press **e**. You may do whatever is necessary to put the cursor where you want it to go: window, change views, even locate on another point if you want that point and the new point to be the same. When the cursor is at the desired new location of the point and you press **e**, the screen is redrawn with the point at its new position.

We should mention that the prompt for moving the cursor and pressing **e** will go away if you do something like windowing which causes a new message to come up in the command line. Even though it goes away, the procedure is still in effect.

Relocating sets of elements

The **relocate** command is used to move and turn models, bulkheads (if the model is that type), or the entire set of models in the computer. It is also used to duplicate a model and place it at another location in whatever orientation you desire. **Relocate** is a powerful command, and we will explain its use with some examples.

Figure 21 shows a rectangular model like the one we

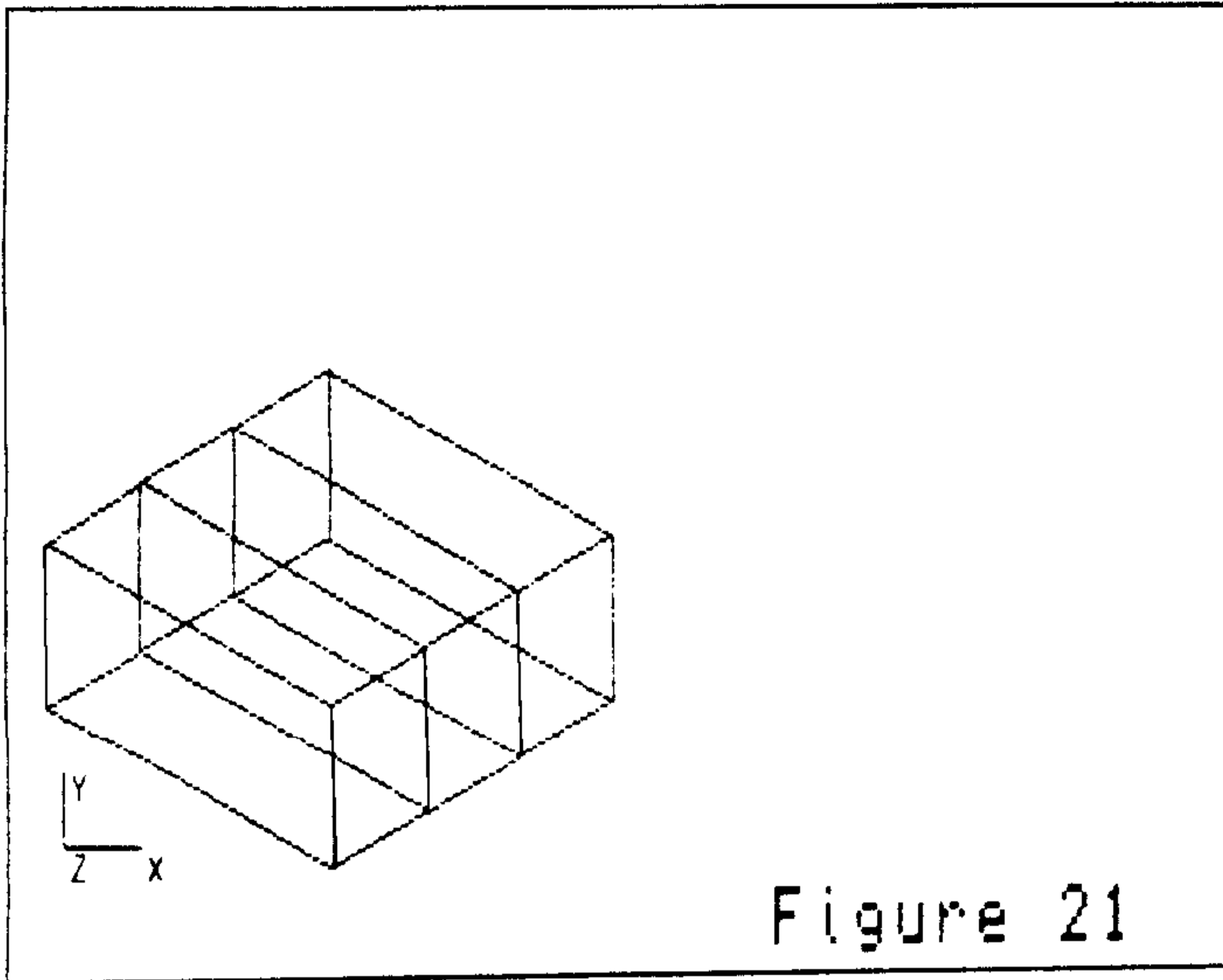

Figure 21

discussed previously. It has been rotated into an isometric and modified back into the front view; this orientation makes what we will do a little more clear. Assuming you have a model like this one on your screen, we will go through some model moving together.

If we put the cursor on one of the points (making it the pivot point) and press r, we are told to move the cursor to the new

location and press r again like we were when editing. The position you pick will be the new location of the pivot point, and the model will be positioned relative to that point, so it really does not matter which point you pick.

After picking a new position off to the right for the pivot point and pressing r again, we get an **add model/move** prompt. Since we are moving a model, key m. The next choice is **model/all/bulkhead**; press m again. Now the rotation prompts start. Rotation in this section of the program is exactly the same as it is in the Rotation Menu, except that instead of rotating about the zero point, we are rotating about the pivot point

that we chose. Let's rotate the model counterclockwise 30 degrees; enter -30 for z rotation. So we have moved the pivot point to the right some distance, the model has followed it over, and then it was turned counterclockwise. The results should look like Figure 22.

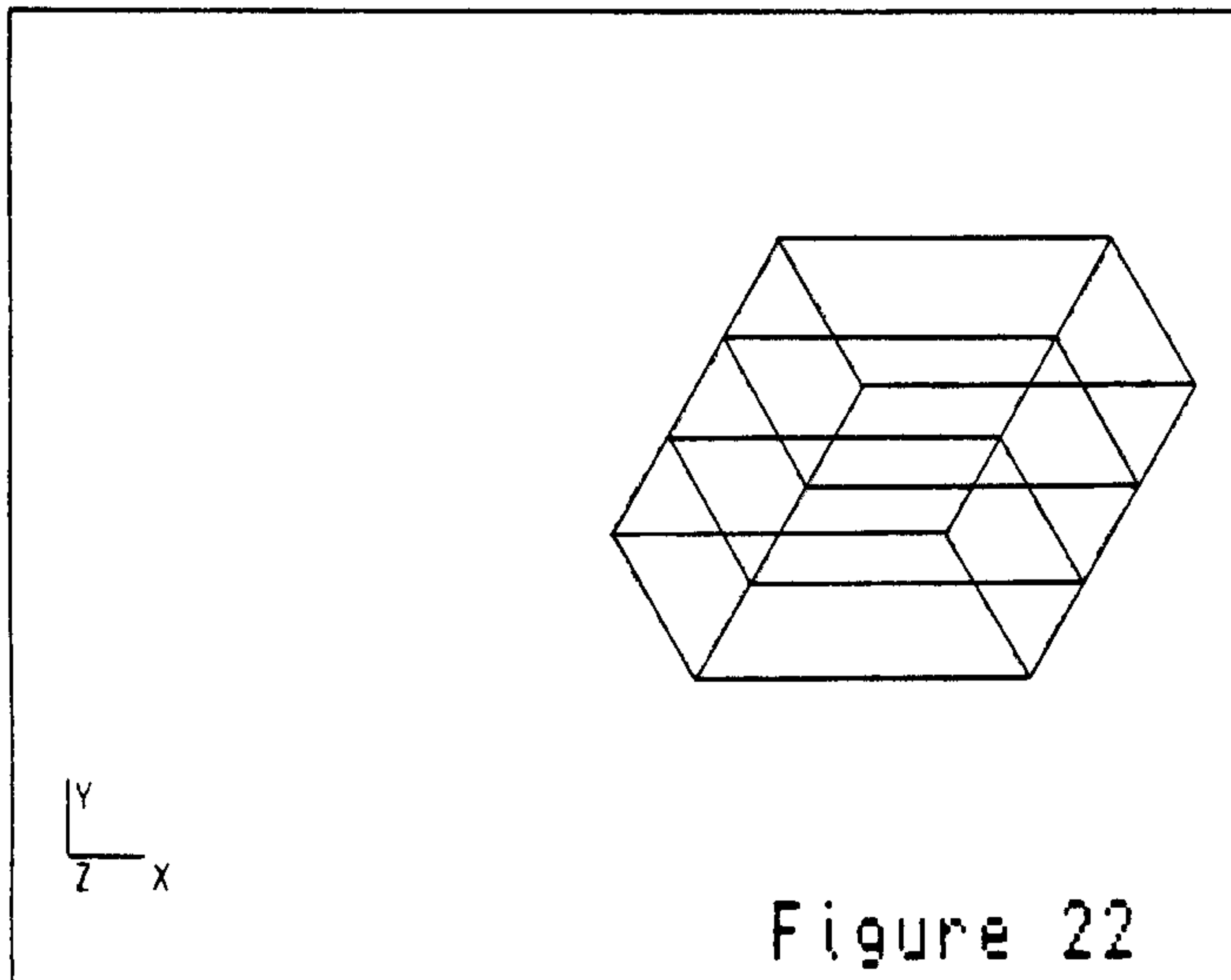

Figure 22

At the **model/all/bulkhead** prompt, if we would have chosen to move everything or one of the bulkheads, the

procedure is exactly the same. Movement is relative so unless you have a specific point you want to turn about

or a specific new location in mind, it does not matter which point you pick. If you want to move a bulkhead, your pivot point should be one of the points in the bulkhead.

The ability to move all of the models is handy for aligning the display when going through the Rotation Menu, since rotation there centers on the 0,0 point. Moving bulkheads is one way to adjust the shape of a complex cell model or surface of revolution.

Now we can try duplicating the model and putting the new model in the position shown in Figure 23. Put

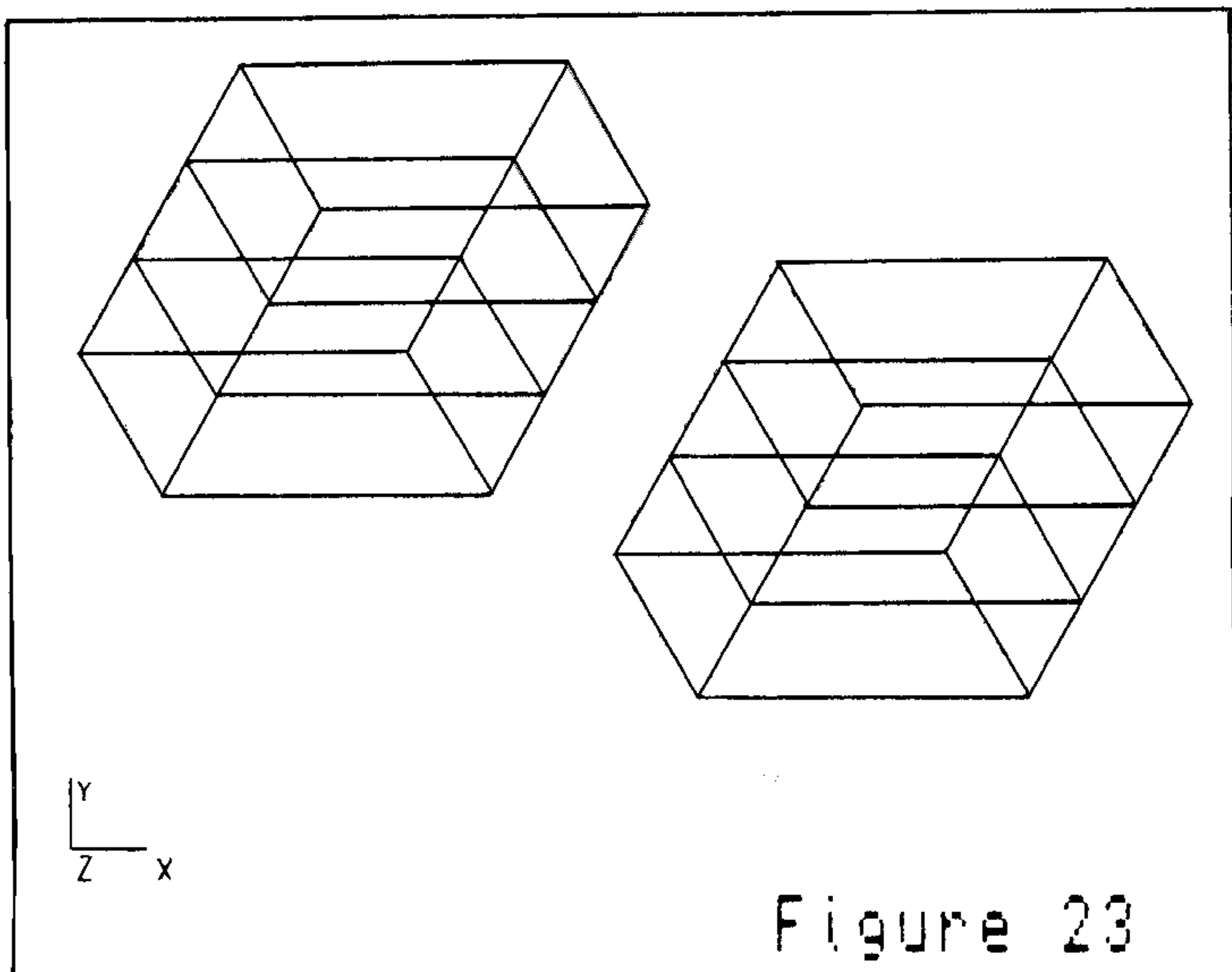

the cursor on a pivot point of the model and press **r** and **c** just as we did before. Move the cursor so the duplicate model will be at the top of the screen like it is in Figure 23 and press **r** again. Press **a** at the prompt to add a new model. The new model is initialized and you are asked to assign it a color. After that, the rotation prompts come up as before; we will not rotate the model this time so press **ENTER** three times. The new

model is then drawn and the screen should look like Figure 23.

Later we will discuss how these techniques were used to create the sailplane demo, but first we will present a couple of other commands used to create the demo.

Scaling

The **get scale** command is used similarly to the other manipulation commands, to scale bulkheads, models, or everything. The only difference is that the relocated pivot point is the location that points are scaled about; its location remains constant once it is set and the affected points expand or contract around it.

If we wanted to scale a bulkhead, we would use **g** to locate a point in that bulkhead similar to the way we have started the other manipulation commands. All we are doing is telling **CONCEPT** which bulkhead we want to

work with so it does not matter which point we pick as long as we know it is in the bulkhead we are interested in. If after pressing **c** to **continue**, we move the cursor to a position inside or outside of the bulkhead, that position will be the reference position for scaling. If the reference position is on a point in the bulkhead and the scale factor (scale factor is asked for right after **model/all/bulkhead**) is equal to .5 (half scale), then the point at the reference position will not move, but all of the other points in the bulkhead will move half way toward the reference point.

Scaling is a 3 dimensional function, so if you only want to change the size of a bulkhead and not modify its depth plane location, which is most often the case, you must keep the cursor in the plane of the bulkhead. That is why bulkhead scaling is best done with the model aligned in one of the standard three views.

To scale a model, pick any point in the model just to identify the model, then after **continueing**, move the cursor to the 3D reference position desired, press **g**, **m**, and enter the scale factor.

When you want to scale everything, picking a pivot point becomes just a formality to get started; it does not matter what model the point is in. Otherwise the procedure is the same as it is for scaling a model, except that you would key an **a** at **model/all/bulkhead**.

Defining angles

Sometimes you will probably find it necessary to create elements of a model in views other than front, top, or side. In **CONCEPT** you cannot create any views other than those, but you can get the same effect by turning the model using **relocate**. To determine what angle you need to turn the model, you can use the **define angle (/def angle/)** command which displays the angle between a horizontal line and any 2 points or cursor locations on the screen.

Figure 24 shows how **def angle** works. The first

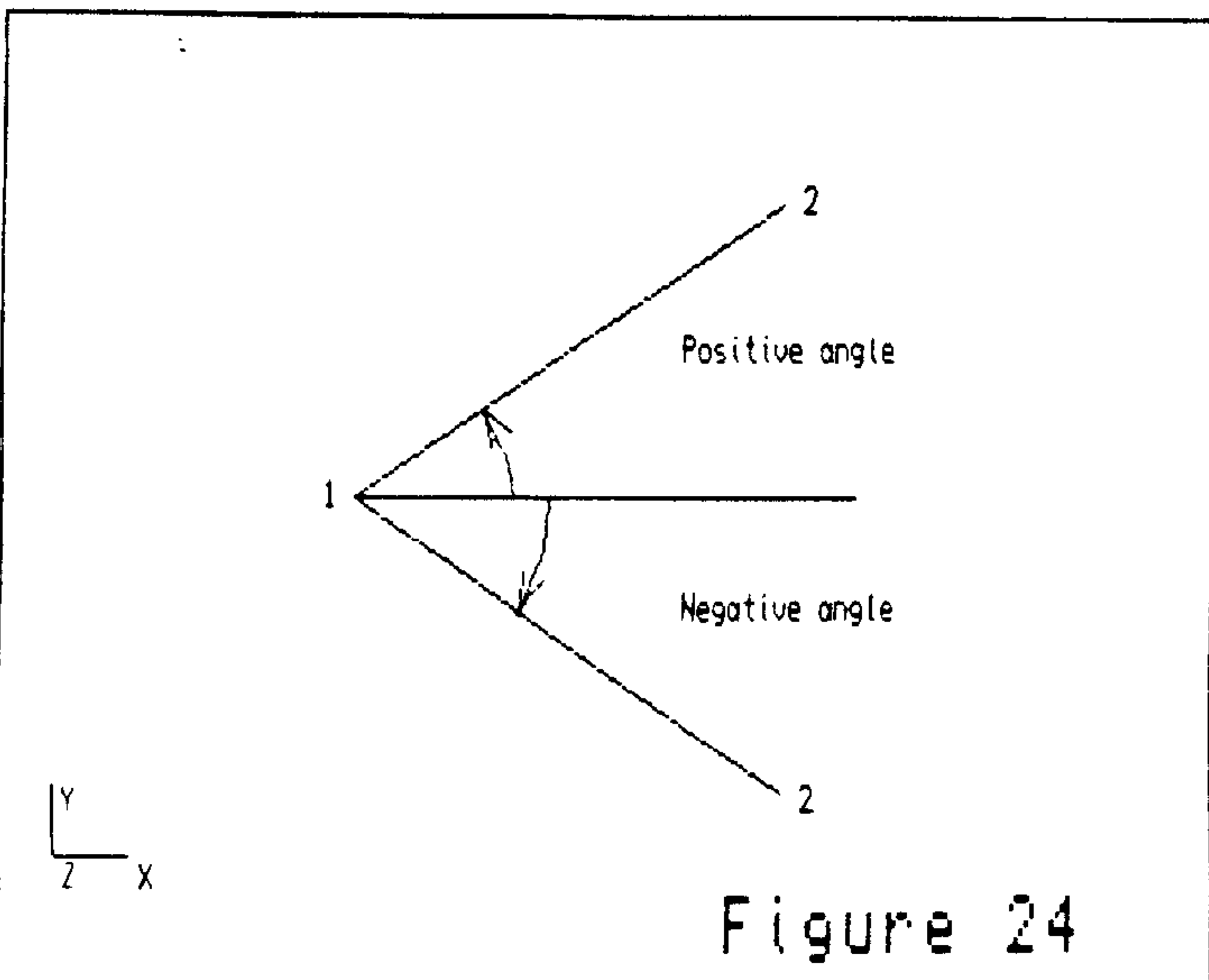

Figure 24

of the screen. The angle is measured from the horizontal line on the right of the pivot point to the line defined by points 1 and 2. If point 2 is above point 1, the angle is measured counterclockwise and is positive. If point 2 is below point 1, the angle is measured clockwise and is negative.

Let's try an example using **def angle**. Figure 25

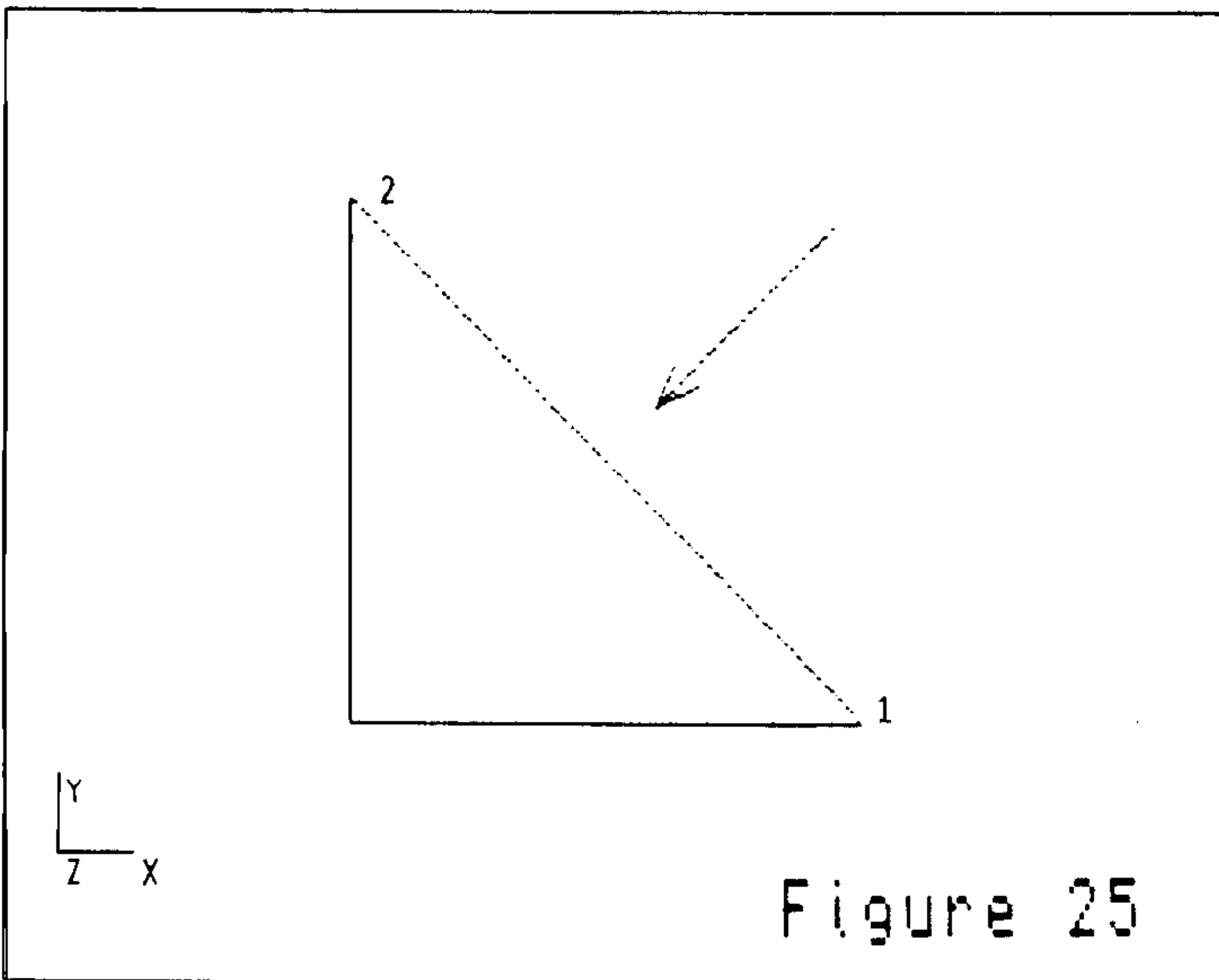
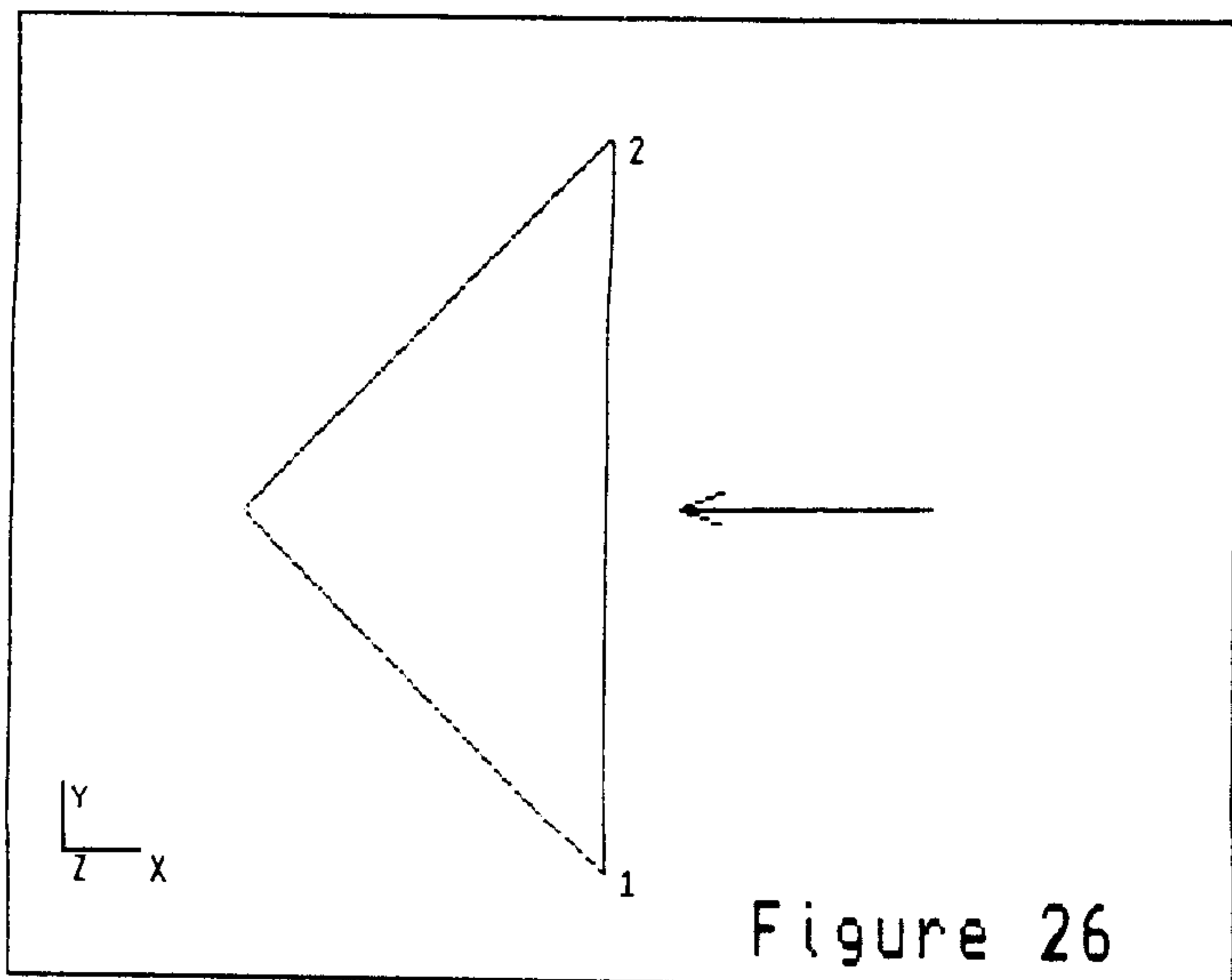

Figure 25

point you pick by moving the cursor to it and pressing **d** becomes the pivot point (point 1 in Figure 24), and it defines a location which is the start point of an imaginary horizontal line heading to the right. The second point picked, again by moving the cursor to it and pressing **d**, defines an imaginary line between points 1 and 2. Once the second point is picked, the angle is displayed in white on the top information line

shows a front view of a cell model with a triangular cross section with equal length legs (for simplicity). We would like to add another cell model adjacent to the sloping face, and to do that it would be most convenient to have the right side view be looking in the direction of the arrow. If we use **def angle** on points 1 and 2 in the figure, the angle of the line is displayed as 135 degrees (counterclockwise from horizontal).



Now we can use **relocate** to turn the model 135-90 or 45 degrees clockwise. Since we are in the front view, the rotation would be positive 45 degrees about the z axis. Figure 26 shows the result. A right side view will be a true view of the now vertical plane.

In the previous example, our accuracy would have been best if we used **loc** and **set point** to put the cursor

exactly on the points before we pressed **d**. You will probably be using coordinate points most often with **def angle** but any cursor locations on the screen will work.

The displayed angle stays in the top line until another angle is defined or until a perspective eyepoint is input and displayed there, so the angle will be there for a while to remind you of what the model's original orientation was.

Model attributes & stipple colors

The one command we have not talked about is **attribute (/attr/)** which is accessed from the Create Menu. **Attr** allows you to change in a model, the attributes of color and whether the model is an open or closed section. After using **attr** the screen is not redrawn, so any color changes will not be displayed until a command is called that redraws the screen.

We have only dealt with single colors so far, and it is a good time to mention that the full range of stipples are also available with **CONCEPT**. The format is like the SuperBasic **INK** and **PAPER** commands without the separating commas:

Color 24 is a red (2) and green (4) stipple of pattern 3 (the default).

Color 160 is a blue (1) and yellow (6) stipple of pattern 0 in 8 color mode. In 4 color mode, the colors are black and white.

Consult your **QL** manual for more details on stipples.

Line work does not generally look good with stipple colors, so model creation can be done with solid colors, and stipple colors can be used for the surfaced display by changing the color of the model to a stipple using `attr` just before rotating.

Although you can set the background color to a stipple, we do not recommend it because the cursor often gets a little hard to see.

Creating a sailplane

The sailplane demo is a good example of how to construct a set of models so that they can be surface modeled properly without using the override command. The demo also can be used to illustrate the steps involved in creating a relatively complex set of models.

In order to save time and get organized right from the start, we made a sketch of one of the views of the sailplane. The sketch is shown in Figure 27. We chose

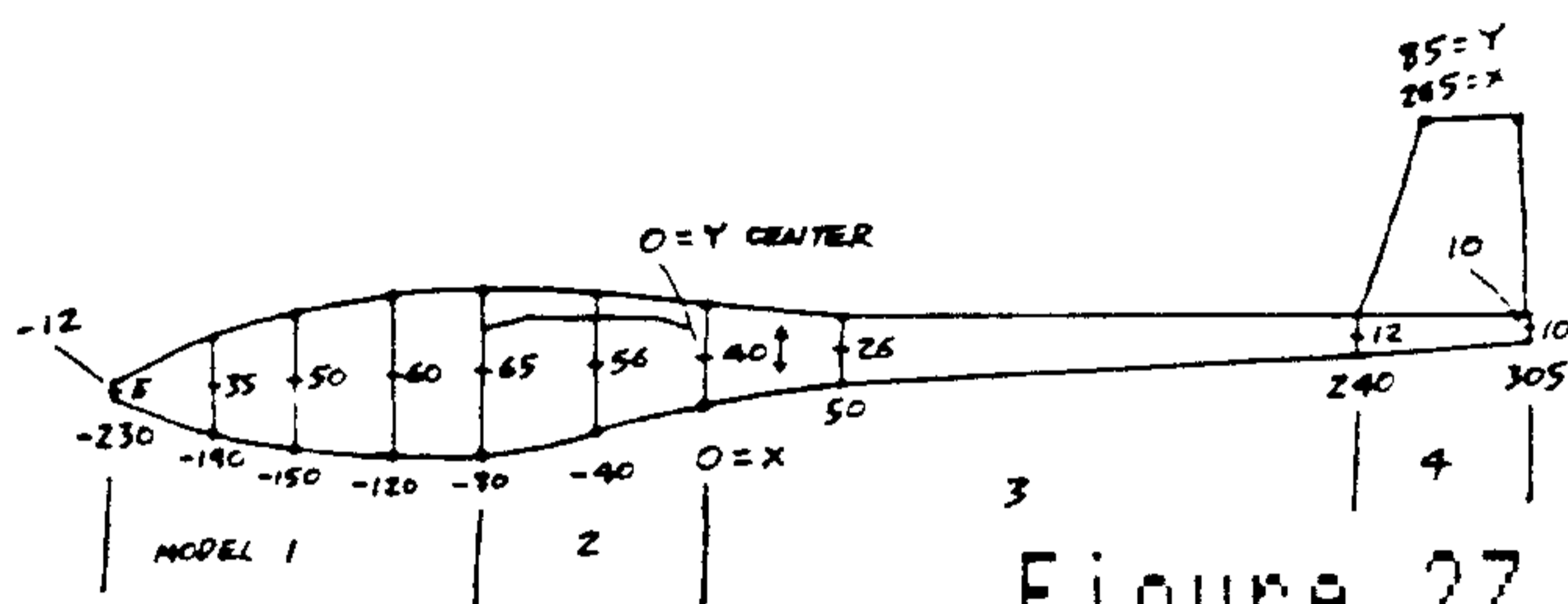

Figure 27

a side view of the fuselage because it gave us all of the information we needed to start working with CONCEPT. The sketch was originally done on gridded paper so that we could estimate the

dimensions. First the overall shape of the side view was sketched, then vertical lines representing the bulkheads were added. More bulkheads are required where the overall shape is more curved. The horizontal position, size, and center point of the bulkheads were then estimated.

The fuselage could have been built as 1 non constant cross section cell model, but we chose to make it 4 separate models as is shown in the sketch. Generally, the farther that the model boundaries are away from other models that may intersect with it (like wings and tail), the more likely it is that the set of models will not surface model correctly in some orientations without using override. A relatively large model like the fuselage generally needs to be broken up into smaller ones if many other models intersect it.

As another example, Figure 28 shows a set of 2

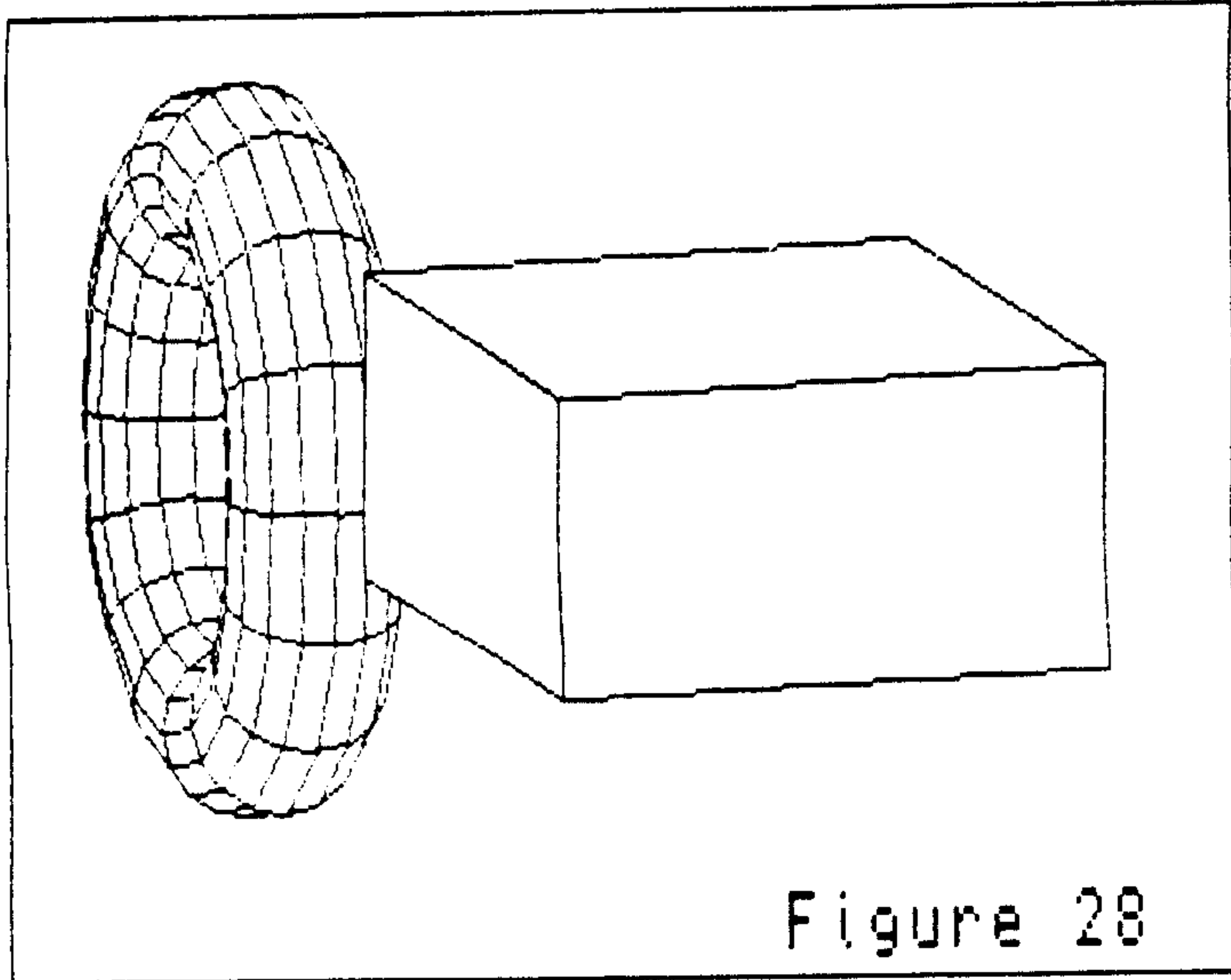

models surfaced. The doughnut shaped model is in front of the box, but because the center of the box is closer to us than the center of the doughnut, the box gets surfaced last and covers the doughnut. Figure 29 shows a solution; the box is split into 2 models. The rear model of the box gets surfaced before the doughnut since its center is behind it, and the front of the box gets surfaced after the doughnut.

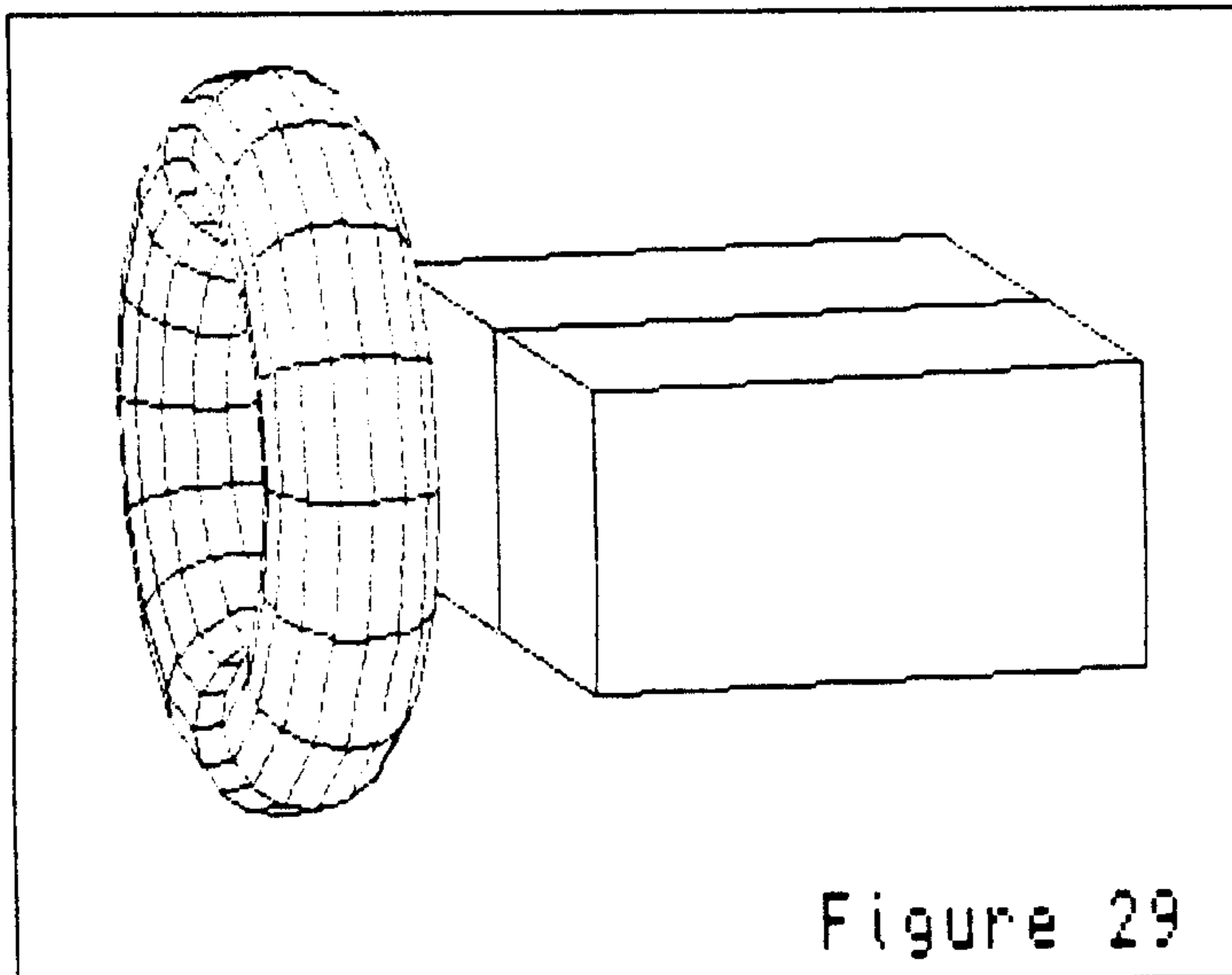

Once we determined model boundaries on the sailplane, it was time to start creating the fuselage. The bulkheads are all ellipses with a horizontal (major) diameter equal to $2/3$ of the vertical (minor) diameter. We set k equal to $2/3$ and multiplied each diameter from the sketch to get the major diameters, when we entered them in the command line. In the front view, knowing the x , y , and z position and size of each

bulkhead from the sketch, we were able to create the entire set of models for the fuselage. We had to remember to start new models where our boundaries were and to go through the Cell Model procedure after creating the first bulkhead in each model.

When all bulkheads in the fuselage had been created, we looked at a side view to see if the shape looked like our sketch. It was close, but we needed to make some adjustments, so we used **relocate** and **get scale** to modify bulkheads until the shape looked good.

Each wing is a single model. The first wing created was built away from the fuselage and moved into place when it was completed. The model was started at the edge that mates with the fuselage. The edge

consists of a point and 3 lines. The non-tapered portion of the wing is a single constant cross section cell with the narrower tip added on afterward. Once the wing was in position on the fuselage, the opposite wing was added from the **relocate** procedure and rotated 180 degrees about the y axis to be in its position on the other side.

Figure 30 is a top view of the wing/fuselage intersection. The base of each wing was squared off when they were created, but we used **edit** to move the coordinates so that they followed the taper of the fuselage.

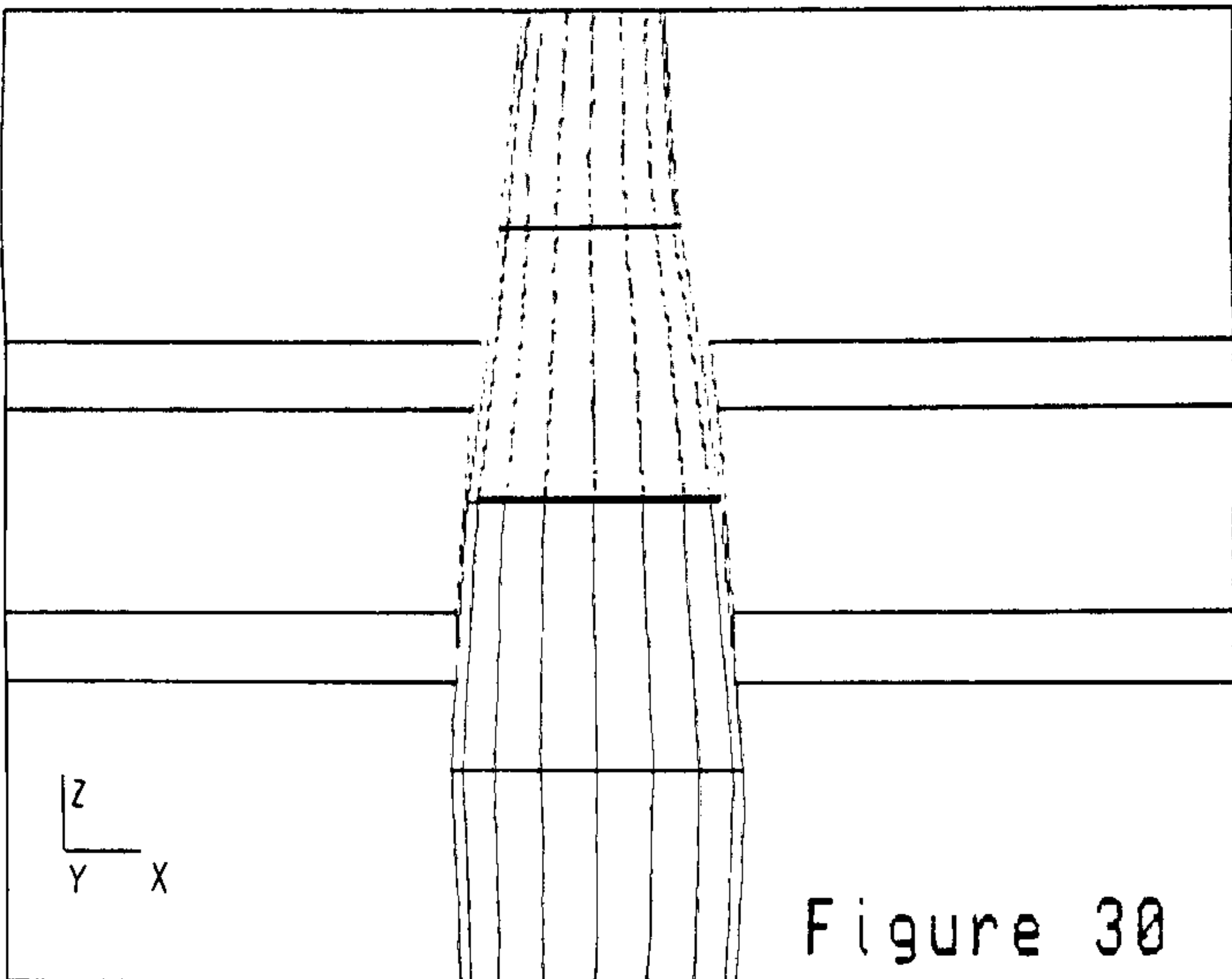

The vertical and horizontal tail surfaces are separate Cell Models created with bulkheads made up of a point and a line. As with the wings, it was easier to create them in an open section of the drawing area and move them into position.

More about surfacing models

In high performance graphics systems, the ultimate model resolution is possible; every pixel acts like one of the rectangular panels that make up a CONCEPT model. To remove hidden surfaces, pixels with x, y, and z position and color attributes can be sorted and displayed in turn. Once you are modeling at the pixel level, you can start thinking about casting shadows, refracting through "glass", and reflecting images off of "shiny" 3D surfaces.

We are not quite to the point of pixel sized models with the QL, but it is a good idea to make our

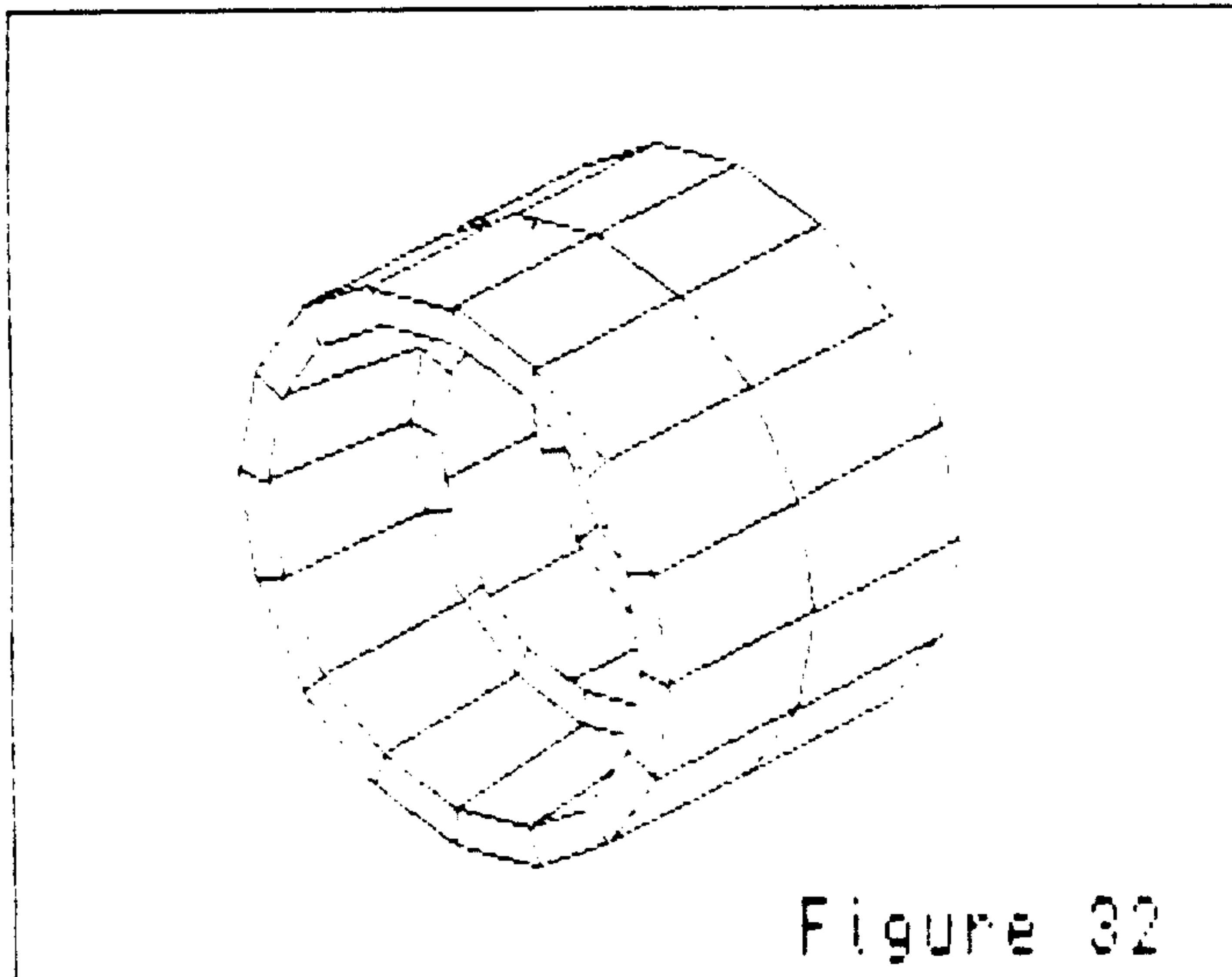
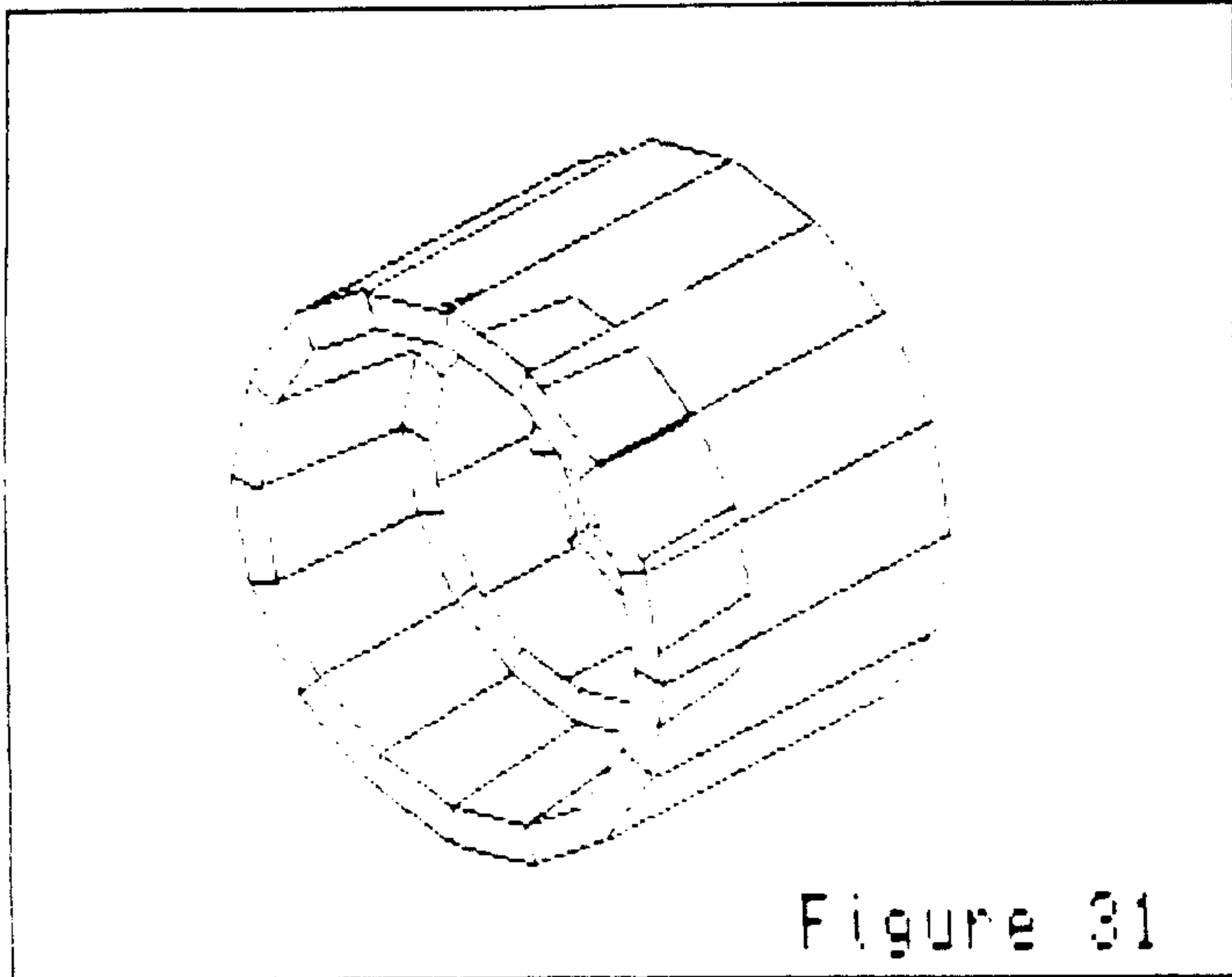

models with relatively small panels (the rectangles that make up the surface of the model) or at least with panels that are consistent in size. Figures 31 and 32 show 2 surfaces of revolution with hidden lines removed. Obviously something is wrong with Figure 31, but Figure 32 is correct. The reason that the model in Figure 31 did not come out correctly is that one section of panels around the outside of the ring is significantly larger than the others in the model. The model in Figure 32 used shorter defining lines in **surf rev** to create the same model, so the panels are more consistent

If you get into a situation like this, you can redraw your new model right over the top of the old one so the new one will have the same overall dimensions. When you are done, just delete the old model.

Quick reference guide

CURSOR MOVEMENT

Up, down, right, and left keys or joystick in CTRL-1. Keys 1-9 are number of pixels moved with each key stroke or key repeat.

MENUS

Create Menu for model creation, Rotation Menu for rotating models into other orientations, and the Display Menu for removing hidden lines and surfaces, adding notes, displaying in perspective, and dumping to a printer.

MODELS

3 types available in Create Menu: cell models, surfaces of revolution, and free form models. Free form models do not use the model building intelligence of the program and are not able to be displayed with hidden lines or surfaces removed.

INPUT

Single key entry for commands; lower case unless command prompt is capitalized. Numeric entry allows one math operator: add, subtract, multiply, divide, or raise to power (+, -, *, /, ^).

CREATE MENU

bkgrd — Sets background color.
background color number: (ENTER to return)

model start — Initializes new model and sets color.
Model color number: (ENTER to return)

DISP — Moves program from Create Menu to Display Menu.

FILES — Save, load, or merge models to and from storage devices.
load/save/merge/cat/drive/return — Sets default storage device (active drive).
— Calls a directory of files on storage device.
— Adds set of models from storage device to current set of models. New set of models is added at current cursor position.
— Saves set of models to storage device.
— Loads set of models from storage device. Current set of models (if any) in QL are eliminated.

ROTATE — Sends program to Rotation Menu.

window — Changes viewing scale of screen and centers screen on cursor.
Key size or ENTER: (1 is full scale, 2 is half scale, 1/3 is 3 times scale, etc.)

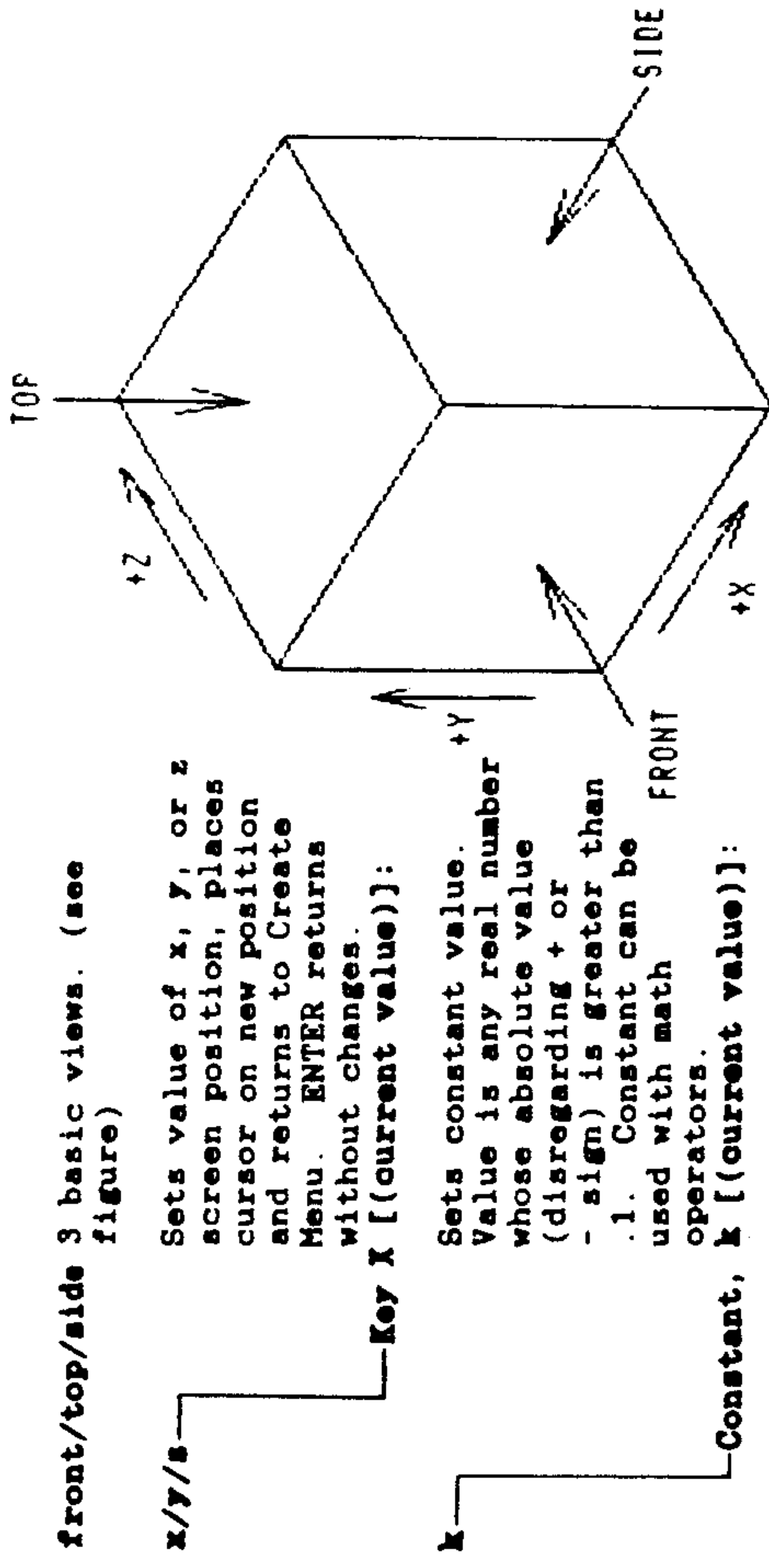

front/top/side 3 basic views. (see figure)

x/y/z — Sets value of x, y, or z screen position, places cursor on new position and returns to Create Menu. ENTER returns without changes.
Key X [(current value)]:

k — Sets constant value. Value is any real number whose absolute value (disregarding + or - sign) is greater than .1. Constant can be used with math operators.
Constant, k [(current value)]:

Point — Places point in current model color on 3D cursor position. Required as first element in model unless model is started with a circle, ellipse, or box.

circle — Draws circles and ellipses in current model color with 3D cursor at center.
circle/ellipse/return — major dia: — minor dia: — tilt angle: — diameter:

F2band — Turns rubber band from previous coordinate to 3D cursor position, on or off.

F6draw — Draws a line from previous coordinate to 3D cursor position in current model color.

F4del — Deletes lines and points in reverse order of creation. Does not delete first point in model.

[F4]rstr — Shifted F4. Restores lines and points after deleting with F4.

BOX — Draws a 2D box with the cursor centered within it.
width: — height:

CELLS — Defines current model as a cell model. Should be keyed after first 2D bulkhead is created.
constant cross section?(y/n/escape)

open ended/closed ended — open ended/closed ended
depth(+for pos dir, -for neg): — number of cells: —
Return to Create Menu.

SURF REV Defines current model as a surface of revolution and displays an axis. After keying S again, all elements created are swept all or part way around axis to form the model.
Angle of rev(ENTER=360 deg):

ZAP Erases all models or deletes one at a time.
erase all/delete model/return
models(ENTER to escape):
 (model #'s above the one deleted are reduced by 1 to eliminate "holes" in model structure)

loc Finds coordinate at or near cursor position and displays x, y, z, and model number.
X: Y: Z: locate/set point/return (hi-res only)
 Places 3D cursor on point.
 Locate a point at a different depth.

relocate Relocates a model in 3D moving and/or rotating it, or copies a model and moves and/or rotates it into new 3D position
model X: Y: Z: continue/locate/return (hi res only) locate pivot point at new depth.
add model/move Move cursor to new location and press 'r'
Model color number: model/all/bulkhead
Model color number: Enter rotation angle about Y:
 Angle about X: (ENTER=0° for all)
 Angle about Z:

edit Moves a single coordinate in 3D space.
model X: Y: Z: continue/locate/return (hi res only)
Move cursor to reference point and press 'e'

get scale Scales a model, bulkhead, or everything. Element is identified and cursor is moved to scaling center point (reference point).
model X: Y: Z: continue/locate/return (hi res only)
Move cursor to reference point and press 'g'
Scale factor:

attr Resets model color and whether model is open or closed section.

hi-lo Switches between hi res (4 color) and lo res (8 color) modes.

ROTATION MENU

rotate Rotates all models in 3D from a front view reference centering on point 0,0,0.
Enter rotation angle about Y:
About X:
About Z:
 (ENTER=0° for all)

isometric Rotates all models to an isometric projection from a front view reference centering on 0,0,0.
create menu Returns program to the Create Menu.

DISPLAY MENU

window Changes viewing distance of screen and centers on cursor.
 Redefines eyepoint when perspective is on.
Key size or ENTER:
 (1 is normal viewing distance, 2 is twice normal, .5 is half normal viewing distance)

persp Allows setting of eyepoint distance for 3D perspective
Enter eyepoint distance(0=off): (distance to model coordinate nearest screen)

surf Eliminates hidden surfaces. Models are drawn with rectangular panels of model color bordered with black or white depending on background and model color. ENTER halts execution.

line Eliminates hidden lines. ENTER halts execution.

override Allows you to select sequence of models to be surface or line modeled if necessary.
override/reset Puts modeling back into automatic mode.
Models(): (asks sequence of all models; number one gets modeled first)

txt Prints any current notes and allows entry of up to 20 notes of 34 characters in any of 5 text sizes anywhere on the screen. Position, color, and size can be changed.
input/change/return Back to Display Menu.
[>][<]/(ENTER)/delete/return Deletes current text.
[] Selects current text. (enter text)
Color number: (0 through 7 only)
Chr size(1,2,3,4,5): (1 is smallest, 5 is largest)

dump Prints screen to Epson compatible printer using the Easel screen dump program.
Put EASEL in MDV1 & press any key Go/return

rtn Returns to the Rotation Menu.